

The University of the State of New York
REGENTS HIGH SCHOOL EXAMINATION

PHYSICAL SETTING PHYSICS

Thursday, June 21, 2007 — 9:15 a.m. to 12:15 p.m., only

The answer sheet for Part A and Part B–1 is the last page of this examination booklet. Turn to the last page and fold it along the perforations. Then, slowly and carefully, tear off the answer sheet and fill in the heading.

The answer booklet for Part B–2 and Part C is stapled in the center of this examination booklet. Open the examination booklet, carefully remove the answer booklet, and close the examination booklet. Then fill in the heading of your answer booklet.

You are to answer *all* questions in all parts of this examination according to the directions provided in the examination booklet. Record your answers to the Part A and Part B–1 multiple-choice questions on your separate answer sheet. Write your answers to the Part B–2 and Part C questions in your answer booklet. All work should be written in pen, except for graphs and drawings, which should be done in pencil. You may use scrap paper to work out the answers to the questions, but be sure to record all your answers on the answer sheet and in the answer booklet.

When you have completed the examination, you must sign the statement printed at the end of your separate answer sheet, indicating that you had no unlawful knowledge of the questions or answers prior to the examination and that you have neither given nor received assistance in answering any of the questions during the examination. Your answer sheet and answer booklet cannot be accepted if you fail to sign this declaration.

Notice . . .

A scientific or graphing calculator, a centimeter ruler, a protractor, and a copy of the *2006 Edition Reference Tables for Physical Setting/Physics*, which you may need to answer some questions in this examination, must be available for your use while taking this examination.

The use of any communications device is strictly prohibited when taking this examination. If you use any communications device, no matter how briefly, your examination will be invalidated and no score will be calculated for you.

DO NOT OPEN THIS EXAMINATION BOOKLET UNTIL THE SIGNAL IS GIVEN.

Part A

Answer all questions in this part.

Directions (1–35): For each statement or question, write on the separate answer sheet the *number* of the word or expression that, of those given, best completes the statement or answers the question.

1 Which is *not* a vector quantity?

- (1) electric charge
- (2) magnetic field strength
- (3) velocity
- (4) displacement

2 An astronaut standing on a platform on the Moon drops a hammer. If the hammer falls 6.0 meters vertically in 2.7 seconds, what is its acceleration?

- (1) 1.6 m/s^2
- (2) 2.2 m/s^2
- (3) 4.4 m/s^2
- (4) 9.8 m/s^2

3 A 2.00-kilogram object weighs 19.6 newtons on Earth. If the acceleration due to gravity on Mars is 3.71 meters per second², what is the object's mass on Mars?

- (1) 2.64 kg
- (2) 2.00 kg
- (3) 19.6 N
- (4) 7.42 N

4 A car moves with a constant speed in a clockwise direction around a circular path of radius r , as represented in the diagram below.

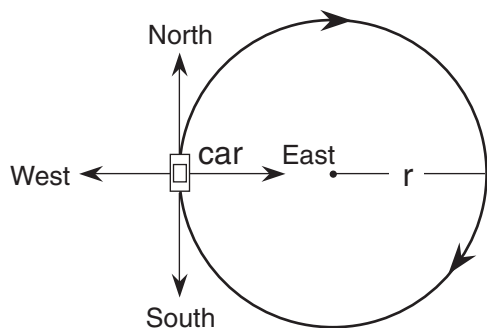

When the car is in the position shown, its acceleration is directed toward the

- (1) north
- (2) west
- (3) south
- (4) east

Note that question 5 has only three choices.

5 As the angle between two concurrent forces decreases, the magnitude of the force required to produce equilibrium

- (1) decreases
- (2) increases
- (3) remains the same

6 A child walks 5.0 meters north, then 4.0 meters east, and finally 2.0 meters south. What is the magnitude of the resultant displacement of the child after the entire walk?

- (1) 1.0 m
- (2) 5.0 m
- (3) 3.0 m
- (4) 11.0 m

7 The diagram below represents a spring hanging vertically that stretches 0.075 meter when a 5.0-newton block is attached. The spring-block system is at rest in the position shown.

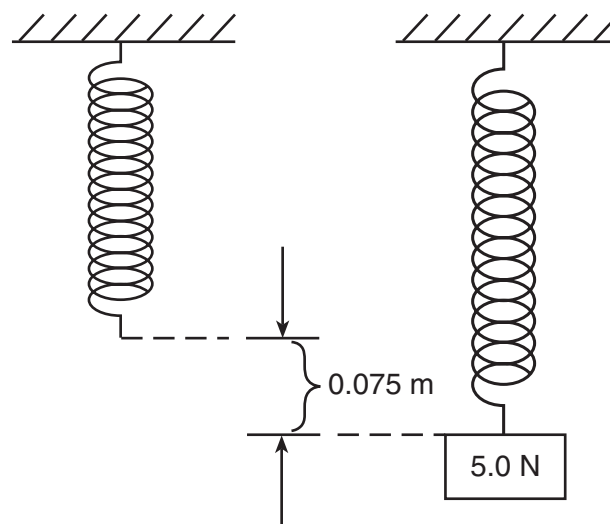

The value of the spring constant is

- (1) 38 N/m
- (2) 67 N/m
- (3) 130 N/m
- (4) 650 N/m

8 A 0.50-kilogram object moves in a horizontal circular path with a radius of 0.25 meter at a constant speed of 4.0 meters per second. What is the magnitude of the object's acceleration?

- (1) 8.0 m/s^2 (3) 32 m/s^2
 (2) 16 m/s^2 (4) 64 m/s^2

9 Which situation will produce the greatest change of momentum for a 1.0-kilogram cart?

- (1) accelerating it from rest to 3.0 m/s
 (2) accelerating it from 2.0 m/s to 4.0 m/s
 (3) applying a net force of 5.0 N for 2.0 s
 (4) applying a net force of 10.0 N for 0.5 s

10 Earth's mass is approximately 81 times the mass of the Moon. If Earth exerts a gravitational force of magnitude F on the Moon, the magnitude of the gravitational force of the Moon on Earth is

- (1) F (3) $9F$
 (2) $\frac{F}{81}$ (4) $81F$

11 The table below lists the mass and speed of each of four objects.

Data Table

Objects	Mass (kg)	Speed (m/s)
A	1.0	4.0
B	2.0	2.0
C	0.5	4.0
D	4.0	1.0

Which two objects have the same kinetic energy?

- (1) A and D (3) A and C
 (2) B and D (4) B and C

12 A horizontal force of 5.0 newtons acts on a 3.0-kilogram mass over a distance of 6.0 meters along a horizontal, frictionless surface. What is the change in kinetic energy of the mass during its movement over the 6.0-meter distance?

- (1) 6.0 J (3) 30. J
 (2) 15 J (4) 90. J

13 Which quantity is a measure of the rate at which work is done?

- (1) energy (3) momentum
 (2) power (4) velocity

14 The diagram shows two bowling balls, A and B, each having a mass of 7.00 kilograms, placed 2.00 meters apart.

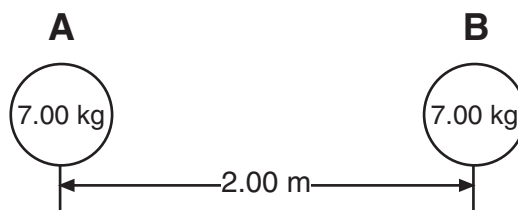

What is the magnitude of the gravitational force exerted by ball A on ball B?

- (1) $8.17 \times 10^{-9} \text{ N}$ (3) $8.17 \times 10^{-10} \text{ N}$
 (2) $1.63 \times 10^{-9} \text{ N}$ (4) $1.17 \times 10^{-10} \text{ N}$

15 If 1.0 joule of work is required to move 1.0 coulomb of charge between two points in an electric field, the potential difference between the two points is

- (1) $1.0 \times 10^0 \text{ V}$ (3) $6.3 \times 10^{18} \text{ V}$
 (2) $9.0 \times 10^9 \text{ V}$ (4) $1.6 \times 10^{-19} \text{ V}$

16 The current through a 10.-ohm resistor is 1.2 amperes. What is the potential difference across the resistor?

- (1) 8.3 V (3) 14 V
 (2) 12 V (4) 120 V

17 A copper wire of length L and cross-sectional area A has resistance R . A second copper wire at the same temperature has a length of $2L$ and a cross-sectional area of $\frac{1}{2}A$. What is the resistance of the second copper wire?

- (1) R (2) $2R$ (3) $\frac{1}{2}R$ (4) $4R$

18 A 6.0-ohm lamp requires 0.25 ampere of current to operate. In which circuit below would the lamp operate correctly when switch S is closed?

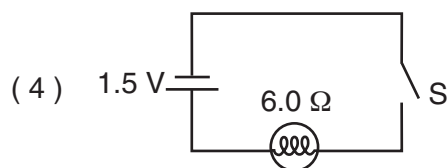
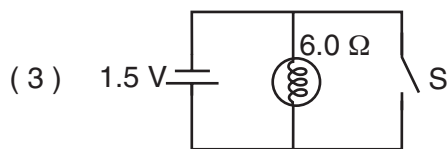
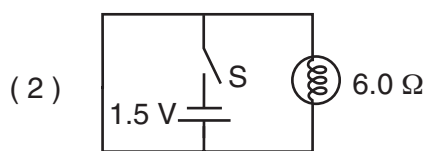
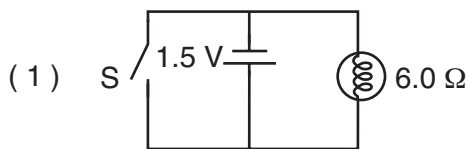

19 What is the total current in a circuit consisting of six operating 100-watt lamps connected in parallel to a 120-volt source?

- (1) 5 A (2) 20 A (3) 600 A (4) 12 000 A

20 A 4.50-volt personal stereo uses 1950 joules of electrical energy in one hour. What is the electrical resistance of the personal stereo?

- (1) 433 Ω (2) 96.3 Ω (3) 37.4 Ω (4) 0.623 Ω

Note that question 21 has only three choices.

21 As yellow light ($f = 5.09 \times 10^{14}$ Hz) travels from zircon into diamond, the speed of the light

- (1) decreases (2) increases (3) remains the same

22 The diagram below represents a transverse wave.

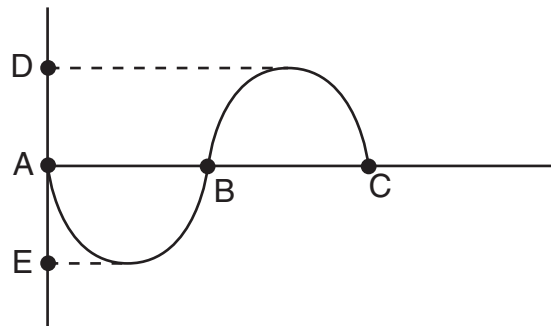

The distance between which two points identifies the amplitude of the wave?

- (1) A and B (2) A and C (3) A and E (4) D and E

23 The diagram below represents a periodic wave.

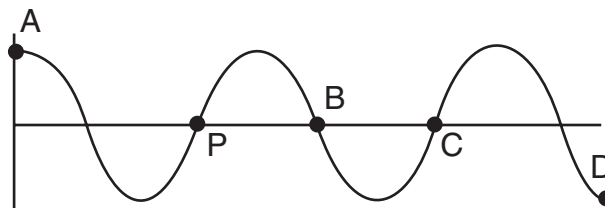

Which point on the wave is in phase with point P ?

- (1) A (2) B (3) C (4) D

24 What is the period of a 60.-hertz electromagnetic wave traveling at 3.0×10^8 meters per second?

- (1) 1.7×10^{-2} s (3) 6.0×10^1 s
(2) 2.0×10^{-7} s (4) 5.0×10^6 s

25 At an outdoor physics demonstration, a delay of 0.50 second was observed between the time sound waves left a loudspeaker and the time these sound waves reached a student through the air. If the air is at STP, how far was the student from the speaker?

- (1) 1.5×10^{-3} m (3) 6.6×10^2 m
(2) 1.7×10^2 m (4) 1.5×10^8 m

26 A microwave and an x ray are traveling in a vacuum. Compared to the wavelength and period of the microwave, the x ray has a wavelength that is

- (1) longer and a period that is shorter
(2) longer and a period that is longer
(3) shorter and a period that is longer
(4) shorter and a period that is shorter

27 Which type of wave requires a material medium through which to travel?

- (1) electromagnetic (3) sound
(2) infrared (4) radio

28 A car traveling at 70 kilometers per hour accelerates to pass a truck. When the car reaches a speed of 90 kilometers per hour the driver hears the glove compartment door start to vibrate. By the time the speed of the car is 100 kilometers per hour, the glove compartment door has stopped vibrating. This vibrating phenomenon is an example of

- (1) the Doppler effect
(2) diffraction
(3) resonance
(4) destructive interference

29 A beam of monochromatic light approaches a barrier having four openings, A, B, C, and D, of different sizes as shown below.

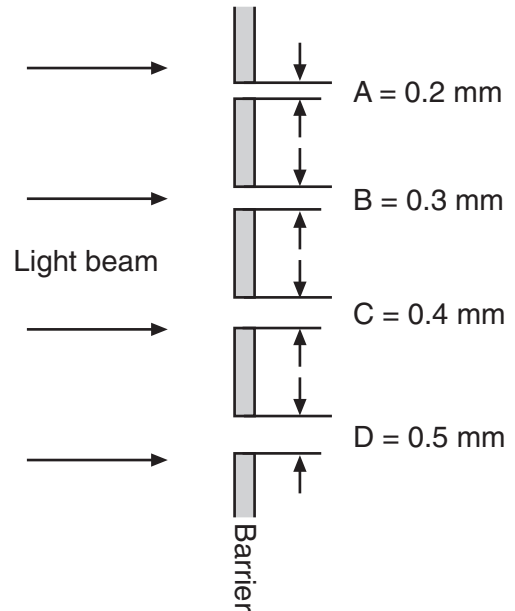

Which opening will cause the greatest diffraction?

- (1) A (3) C
(2) B (4) D

30 Two waves having the same frequency and amplitude are traveling in the same medium. Maximum constructive interference occurs at points where the phase difference between the two superposed waves is

- (1) 0° (3) 180°
(2) 90° (4) 270°

31 A student sees a train that is moving away from her and sounding its whistle at a constant frequency. Compared to the sound produced by the whistle, the sound observed by the student is

- (1) greater in amplitude
(2) a transverse wave rather than a longitudinal wave
(3) higher in pitch
(4) lower in pitch

Part B-1

Answer all questions in this part.

Directions (36–46): For *each* statement or question, write on the separate answer sheet the *number* of the word or expression that, of those given, best completes the statement or answers the question.

36 What is the approximate length of a baseball bat?

- (1) 10^{-1} m (3) 10^1 m
 (2) 10^0 m (4) 10^2 m

37 A force of 1 newton is equivalent to 1

- (1) $\frac{\text{kg} \cdot \text{m}}{\text{s}^2}$ (3) $\frac{\text{kg} \cdot \text{m}^2}{\text{s}^2}$
 (2) $\frac{\text{kg} \cdot \text{m}}{\text{s}}$ (4) $\frac{\text{kg}^2 \cdot \text{m}^2}{\text{s}^2}$

Base your answers to questions 38 and 39 on the information below.

A stream is 30. meters wide and its current flows southward at 1.5 meters per second. A toy boat is launched with a velocity of 2.0 meters per second eastward from the west bank of the stream.

38 What is the magnitude of the boat's resultant velocity as it crosses the stream?

- (1) 0.5 m/s (3) 3.0 m/s
 (2) 2.5 m/s (4) 3.5 m/s

39 How much time is required for the boat to reach the opposite bank of the stream?

- (1) 8.6 s (3) 15 s
 (2) 12 s (4) 60. s

40 An observer recorded the following data for the motion of a car undergoing constant acceleration.

Time (s)	Speed (m/s)
3.0	4.0
5.0	7.0
6.0	8.5

What was the magnitude of the acceleration of the car?

- (1) 1.3 m/s^2 (3) 1.5 m/s^2
 (2) 2.0 m/s^2 (4) 4.5 m/s^2

41 Which graph best represents the relationship between the velocity of an object thrown straight upward from Earth's surface and the time that elapses while it is in the air? [Neglect friction.]

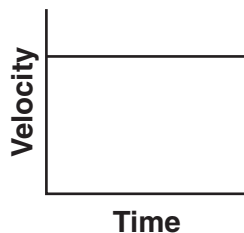

(1)

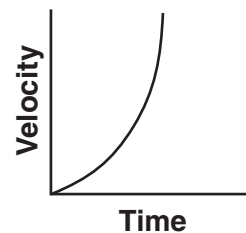

(3)

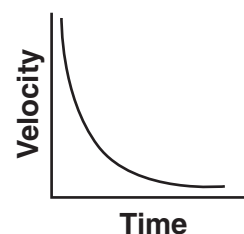

(2)

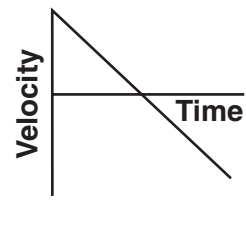

(4)

42 In the diagram below, scaled vectors represent the momentum of each of two masses, A and B, sliding toward each other on a frictionless, horizontal surface.

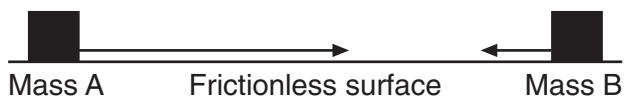

Which scaled vector best represents the momentum of the system after the masses collide?

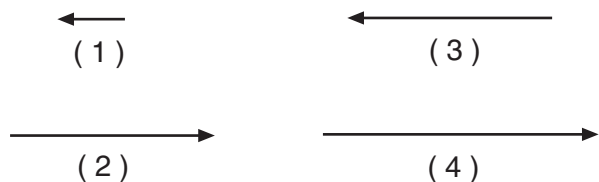

43 A pendulum is pulled to the side and released from rest. Which graph best represents the relationship between the gravitational potential energy of the pendulum and its displacement from its point of release?

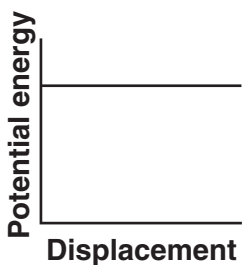

(1)

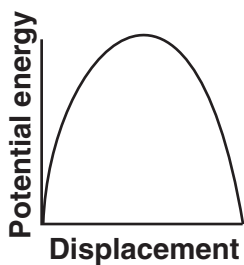

(3)

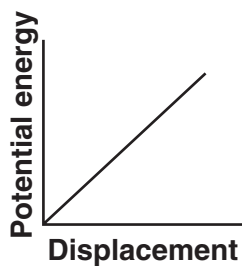

(2)

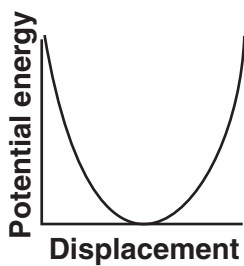

(4)

44 Which graph best represents the relationship between the power required to raise an elevator and the speed at which the elevator rises?

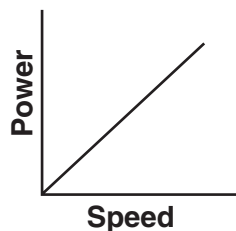

(1)

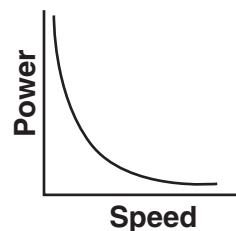

(3)

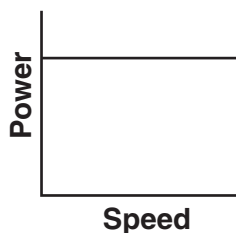

(2)

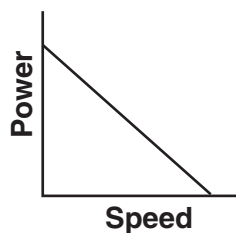

(4)

45 Baryons may have charges of

- (1) $+1e$ and $+\frac{4}{3}e$ (3) $-1e$ and $+1e$
 (2) $+2e$ and $+3e$ (4) $-2e$ and $-\frac{2}{3}e$

46 The slope of a graph of photon energy versus photon frequency represents

- (1) Planck's constant
 (2) the mass of a photon
 (3) the speed of light
 (4) the speed of light squared

Part B-2

Answer all questions in this part.

Directions (47–60): Record your answers in the spaces provided in your answer booklet.

Base your answers to questions 47 and 48 on the information below.

The magnitude of the electric field strength between two oppositely charged parallel metal plates is 2.0×10^3 newtons per coulomb. Point *P* is located midway between the plates.

47 On the diagram *in your answer booklet*, sketch *at least five* electric field lines to represent the field between the two oppositely charged plates. [Draw an arrowhead on each field line to show the proper direction.] [1]

48 An electron is located at point *P* between the plates. Calculate the magnitude of the force exerted on the electron by the electric field. [Show all work, including the equation and substitution with units.] [2]

Base your answers to questions 49 through 51 on the information below.

A student generates a series of transverse waves of varying frequency by shaking one end of a loose spring. All the waves move along the spring at a speed of 6.0 meters per second.

49 Complete the data table *in your answer booklet*, by determining the wavelengths for the frequencies given. [1]

50 On the grid *in your answer booklet*, plot the data points for wavelength versus frequency. [1]

51 Draw the best-fit line or curve. [1]

Base your answers to questions 52 and 53 on the information and diagram below.

A force of 60. newtons is applied to a rope to pull a sled across a horizontal surface at a constant velocity. The rope is at an angle of 30. degrees above the horizontal.

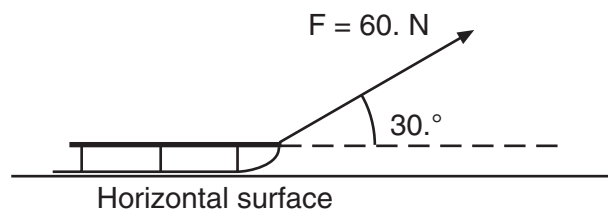

52 Calculate the magnitude of the component of the 60.-newton force that is parallel to the horizontal surface. [Show all work, including the equation and substitution with units.] [2]

53 Determine the magnitude of the frictional force acting on the sled. [1]

54 A book sliding across a horizontal tabletop slows until it comes to rest. Describe what change, if any, occurs in the book's kinetic energy and internal energy as it slows. [2]

Base your answers to questions 55 through 57 on the information and diagram below.

A projectile is launched into the air with an initial speed of v_i at a launch angle of $30.^\circ$ above the horizontal. The projectile lands on the ground 2.0 seconds later.



55 On the diagram in your answer booklet, sketch the ideal path of the projectile. [1]

56 How does the maximum altitude of the projectile change as the launch angle is increased from $30.^\circ$ to $45.^\circ$ above the horizontal? [Assume the same initial speed, v_i .] [1]

57 How does the total horizontal distance traveled by the projectile change as the launch angle is increased from $30.^\circ$ to $45.^\circ$ above the horizontal? [Assume the same initial speed, v_i .] [1]

Base your answers to questions 58 through 60 on the information and diagram below.

A 3.0-ohm resistor, an unknown resistor, R , and two ammeters, A_1 and A_2 , are connected as shown with a 12-volt source. Ammeter A_2 reads a current of 5.0 amperes.

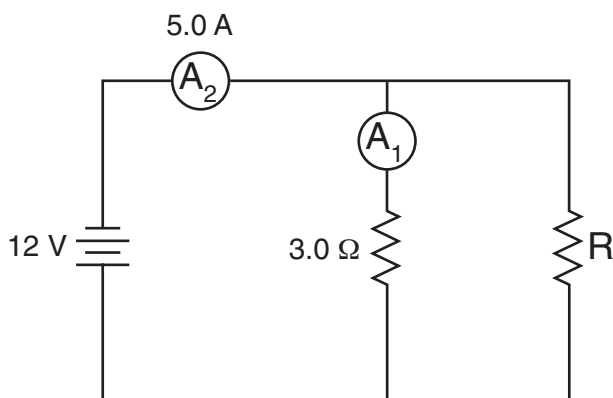

58 Determine the equivalent resistance of the circuit. [1]

59 Calculate the current measured by ammeter A_1 . [Show all work, including the equation and substitution with units.] [2]

60 Calculate the resistance of the unknown resistor, R . [Show all work, including the equation and substitution with units.] [2]

Part C

Answer all questions in this part.

Directions (61–74): Record your answers in the spaces provided in your answer booklet.

Base your answers to question 61 through 65 on the information and diagram below.

A horizontal force of 8.0 newtons is used to pull a 20.-newton wooden box moving toward the right along a horizontal, wood surface, as shown.

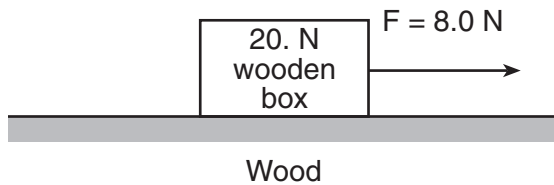

- 61 Starting at point *P* on the diagram *in your answer booklet*, use a metric ruler and a scale of 1.0 cm = 4.0 N to draw a vector representing the normal force acting on the box. Label the vector F_N . [1]
- 62 Calculate the magnitude of the frictional force acting on the box. [Show all work, including the equation and substitution with units.] [2]
- 63 Determine the magnitude of the net force acting on the box. [1]
- 64 Determine the mass of the box. [1]
- 65 Calculate the magnitude of the acceleration of the box. [Show all work, including the equation and substitution with units.] [2]
-

Base your answers to questions 66 and 67 on the information and diagram below.

A pop-up toy has a mass of 0.020 kilogram and a spring constant of 150 newtons per meter. A force is applied to the toy to compress the spring 0.050 meter.

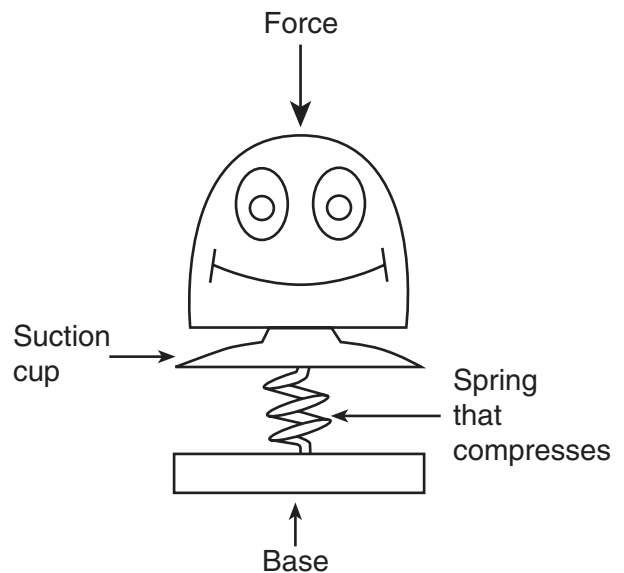

- 66 Calculate the potential energy stored in the compressed spring. [Show all work, including the equation and substitution with units.] [2]
- 67 The toy is activated and all the compressed spring's potential energy is converted to gravitational potential energy. Calculate the maximum vertical height to which the toy is propelled. [Show all work, including the equation and substitution with units.] [2]
-

Base your answers to questions 68 through 71 on the diagram below, which shows a light ray ($f = 5.09 \times 10^{14}$ Hz) in air, incident on a boundary with fused quartz. At the boundary, part of the light is refracted and part of the light is reflected.

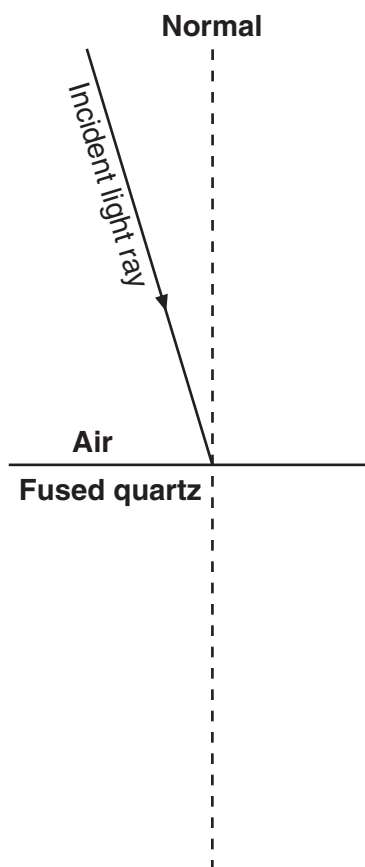

- 68 Using a protractor, measure the angle of incidence of the light ray at the air-fused quartz boundary. [1]
- 69 Calculate the angle of refraction of the incident light ray. [Show all work, including the equation and substitution with units.] [2]
- 70 Using a protractor and straightedge, construct the refracted light ray in the fused quartz on the diagram *in your answer booklet*. [1]
- 71 Using a protractor and straightedge, construct the reflected light ray on the diagram *in your answer booklet*. [1]
-

Base your answers to questions 72 through 74 on the information below.

A photon with a frequency of 5.02×10^{14} hertz is absorbed by an excited hydrogen atom. This causes the electron to be ejected from the atom, forming an ion.

- 72 Calculate the energy of this photon in joules. [Show all work, including the equation and substitution with units.] [2]
- 73 Determine the energy of this photon in electronvolts. [1]
- 74 What is the number of the *lowest* energy level (closest to the ground state) of a hydrogen atom that contains an electron that would be ejected by the absorption of this photon? [1]
-

The University of the State of New York

REGENTS HIGH SCHOOL EXAMINATION

PHYSICAL SETTING
PHYSICS

Thursday, June 21, 2007 — 9:15 a.m. to 12:15 p.m., only

ANSWER SHEET

Student Sex: Male Female Grade

Teacher School

Record your answers to Part A and Part B-1 on this answer sheet.

Part A

- 1 13 25
- 2 14 26
- 3 15 27
- 4 16 28
- 5 17 29
- 6 18 30
- 7 19 31
- 8 20 32
- 9 21 33
- 10 22 34
- 11 23 35
- 12 24

Part A Score

Part B-1

- 36 42
- 37 43
- 38 44
- 39 45
- 40 46
- 41

Part B-1 Score

Write your answers to Part B-2 and Part C in your answer booklet.

The declaration below should be signed when you have completed the examination.

I do hereby affirm, at the close of this examination, that I had no unlawful knowledge of the questions or answers prior to the examination and that I have neither given nor received assistance in answering any of the questions during the examination.

Signature

Tear Here

Tear Here

Tear Here

Tear Here

PHYSICAL SETTING PHYSICS

Thursday, June 21, 2007 — 9:15 a.m. to 12:15 p.m., only

ANSWER BOOKLET

Student Sex: Male Female
 Teacher.....
 School..... Grade

Answer all questions in Part B-2 and Part C. Record your answers in this booklet.

Part	Maximum Score	Student's Score
A	35	
B-1	11	
B-2	19	
C	20	
Total Written Test Score (Maximum Raw Score: 85)		<input type="text"/>
Final Score (From Conversion Chart)		<input type="text"/>
Raters' Initials: Rater 1 Rater 2.....		

Part B-2

47

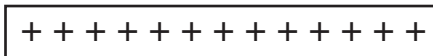

• P

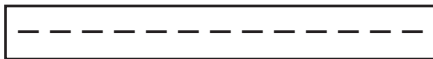

48

49

Data Table	
Frequency (Hz)	Wavelength (m)
1.0	
2.0	
3.0	
6.0	

50-51

Wavelength vs. Frequency

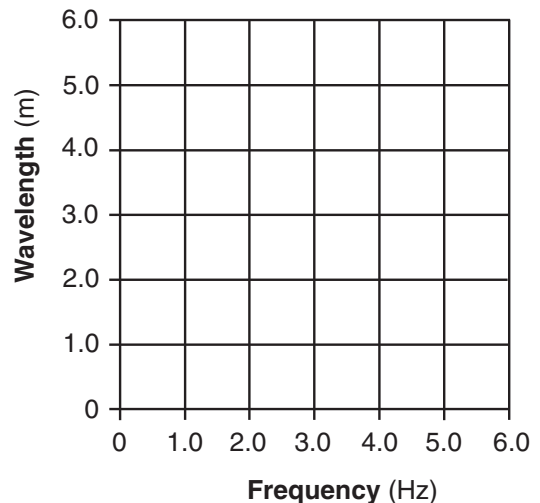

52

53 _____ N

54

55



56

57

58 _____ Ω

59

60

Part C

61



62

63 _____ N

64 _____ kg

65

66

67

68 _____

69

70-71

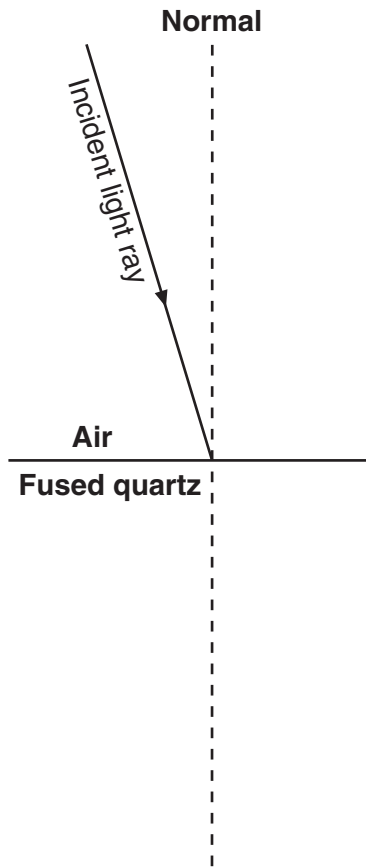

72

73 _____ eV

74 $n =$ _____

FOR TEACHERS ONLY

The University of the State of New York
REGENTS HIGH SCHOOL EXAMINATION

PS-P

PHYSICAL SETTING/PHYSICS

Thursday, June 21, 2007 — 9:15 a.m. to 12:15 p.m., only

SCORING KEY AND RATING GUIDE

Directions to the Teacher:

Refer to the directions on page 3 before rating student papers. Updated information regarding the rating of this examination may be posted on the New York State Education Department's web site during the rating period. Check this web site <http://www.emsc.nysed.gov/osa/> and select the link "Examination Scoring Information" for any recently posted information regarding this examination. This site should be checked before the rating process for this examination begins and several times throughout the Regents examination period.

Part A and Part B-1

Allow 1 credit for each correct response.

Part A			Part B-1	
11	132	252	362	422
21	143	264	371	434
32	151	273	382	441
44	162	283	393	453
52	174	291	403	461
62	184	301	414	
72	191	314		
84	203	322		
93	211	331		
101	223	343		
114	233	351		
123	241			

Directions to the Teacher

Follow the procedures below for scoring student answer papers for the Physical Setting/Physics examination. Additional information about scoring is provided in the publication *Information for Scoring Regents Examinations in the Sciences*.

Use only *red* ink or *red* pencil in rating Regents papers. Do not attempt to *correct* the student's work by making insertions or changes of any kind.

On the detachable answer sheet for Part A and Part B–1, indicate by means of a check mark each incorrect or omitted answer. In the box provided at the end of each part, record the number of questions the student answered correctly for that part.

Students' responses must be scored strictly according to the Scoring Key and Rating Guide. For open-ended questions, credit may be allowed for responses other than those given in the rating guide if the response is a scientifically accurate answer to the question and demonstrates adequate knowledge as indicated by the examples in the rating guide.

Fractional credit is *not* allowed. Only whole-number credit may be given to a response. Units need not be given when the wording of the questions allows such omissions.

Raters should enter the scores earned for Part A, Part B–1, Part B–2, and Part C on the appropriate lines in the box printed on the answer booklet, and then should add these four scores and enter the total in the box labeled "Total Written Test Score." Then, the student's raw score on the written test should be converted to a scaled score by using the conversion chart that will be posted on the Department's web site <http://www.emsc.nysed.gov/osa/> on Thursday, June 21, 2007. The student's scaled score should be entered in the labeled box on the student's answer booklet. The scaled score is the student's final examination score.

All student answer papers that receive a scaled score of 60 through 64 **must** be scored a second time. For the second scoring, a different committee of teachers may score the student's paper or the original committee may score the paper, except that no teacher may score the same open-ended questions that he/she scored in the first rating of the paper. The school principal is responsible for assuring that the student's final examination score is based on a fair, accurate, and reliable scoring of the student's answer paper.

Because scaled scores corresponding to raw scores in the conversion chart may change from one examination to another, it is crucial that for each administration, the conversion chart provided for that administration be used to determine the student's final score.

Please refer to the Department publication *Regents Examination in Physical Setting/Physics: Rating Guide for Parts B–2 and C*. This publication can be found on the New York State Education Department web site <http://www.emsc.nysed.gov/osa/scire/sciresearch/phyratg02.pdf>. Teachers should become familiar with this guide before rating students' papers.

Scoring Criteria for Calculations

For each question requiring the student to show *all calculations, including the equation and substitution with units*, apply the following scoring criteria:

- Allow 1 credit for the equation and substitution of values with units. If the equation and/or substitution with units is not shown, do *not* allow this credit.
- Allow 1 credit for the correct answer (number and unit). If the number is given without the unit, do *not* allow this credit.
- Penalize a student only once per equation for omitting units.
- Allow full credit even if the answer is not expressed with the correct number of significant figures.

Part B–2

- 47 [1] Allow 1 credit for drawing *at least five* straight parallel lines perpendicular to the plates and pointing toward the negative plate. The lines must originate and end on the plates.

Example of a 1-credit response:

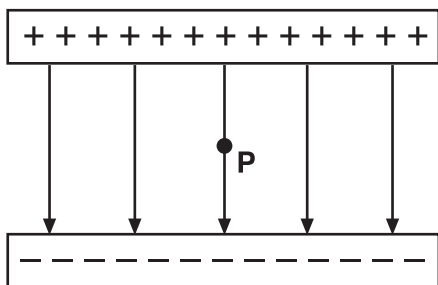

Note: Curved lines beyond the edges of the plates are acceptable.
Parallel lines need not be equally spaced.

- 48 [2] Allow a maximum of 2 credits. Refer to *Scoring Criteria for Calculations* in this rating guide.

Example of a 2-credit response:

$$E = \frac{F_e}{q}$$

$$F_e = Eq$$

$$F_e = (2.0 \times 10^3 \text{ N/C}) (1.6 \times 10^{-19} \text{ C})$$

$$F_e = 3.2 \times 10^{-16} \text{ N}$$

- 49 [1] Allow 1 credit for correctly determining all four wavelengths, as shown below.

Data Table	
Frequency (Hz)	Wavelength (m)
1.0	6.0
2.0	3.0
3.0	2.0
6.0	1.0

- 50 [1] Allow 1 credit for correctly plotting all four data points (± 0.3 grid space).

Note: Allow credit for an answer that is consistent with the student’s response to question 49.

- 51 [1] Allow 1 credit for drawing the best-fit curve.

Note: Allow credit for an answer that is consistent with the student’s response to question 50.

Example of a 2-credit response for questions 50 and 51:

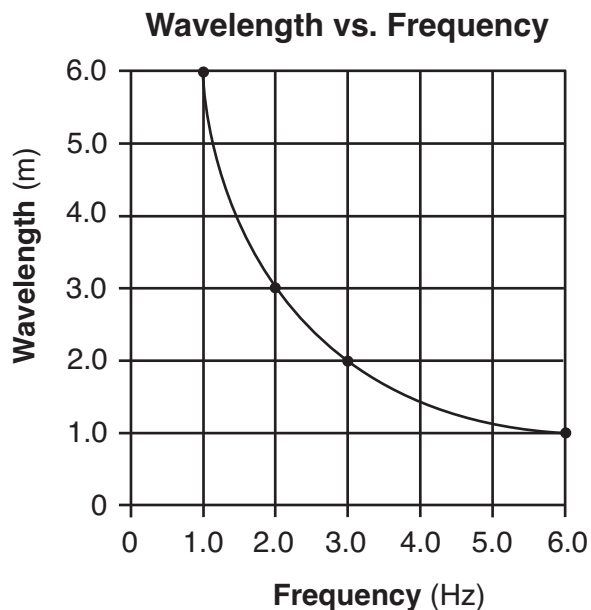

- 52 [2] Allow a maximum of 2 credits. Refer to *Scoring Criteria for Calculations* in this rating guide.

Example of a 2-credit response:

$$A_x = A \cos \theta$$

$$F_x = (60. \text{ N}) \cos 30.^\circ$$

$$F_x = 52 \text{ N}$$

- 53 [1] Allow 1 credit for 52 N *or* an answer that is consistent with the student's response to question 52.

- 54 [2] Allow a maximum of 2 credits, 1 credit for indicating that the kinetic energy decreases and 1 credit for indicating that internal energy increases.

Note: Do not allow credit for indicating that kinetic energy changes into potential energy.

- 55 [1] Allow 1 credit for a parabolic-shaped path.

Example of a 1-credit response:

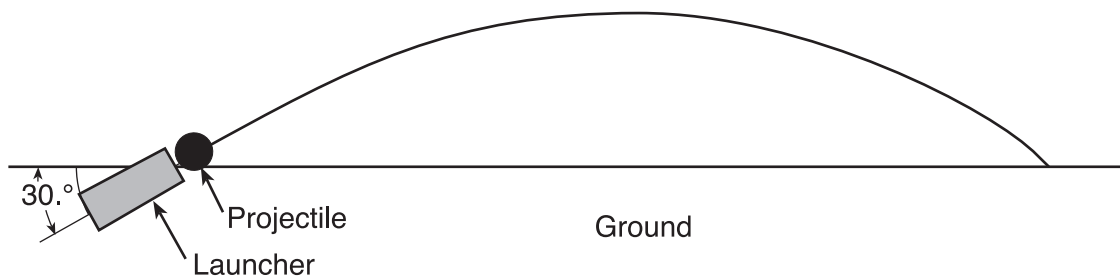

- 56 [1] Allow 1 credit for indicating that the projectile's maximum altitude will increase.

- 57 [1] Allow 1 credit for indicating that the total horizontal distance will increase.

58 [1] Allow 1 credit for 2.4Ω .

59 [2] Allow a maximum of 2 credits. Refer to *Scoring Criteria for Calculations* in this rating guide.

Example of a 2-credit response:

$$R = \frac{V}{I}$$

$$I = \frac{V}{R}$$

$$I = \frac{12 V}{3.0 \Omega}$$

$$I = 4.0 \text{ A}$$

60 [2] Allow a maximum of 2 credits. Refer to *Scoring Criteria for Calculations* in this rating guide.

Examples of 2-credit responses:

$$R = \frac{V}{I} \qquad \frac{1}{R_{eq}} = \frac{1}{R_1} + \frac{1}{R_2}$$

$$R = \frac{12 V}{1.0 \text{ A}} \qquad \text{or} \qquad \frac{1}{R} + \frac{1}{3 \Omega} = \frac{1}{2.4 \Omega}$$

$$R = 12 \Omega \qquad R = 12 \Omega$$

Note: Allow credit for an answer that is consistent with the student's response to question 58 and/or question 59.

Part C

- 61 [1] Allow 1 credit for drawing and labeling a vector 5.0 cm (± 0.2 cm) long, directed upward. Do *not* allow credit if the vector is not labeled or is missing the arrowhead.

Example of a 1-credit response:

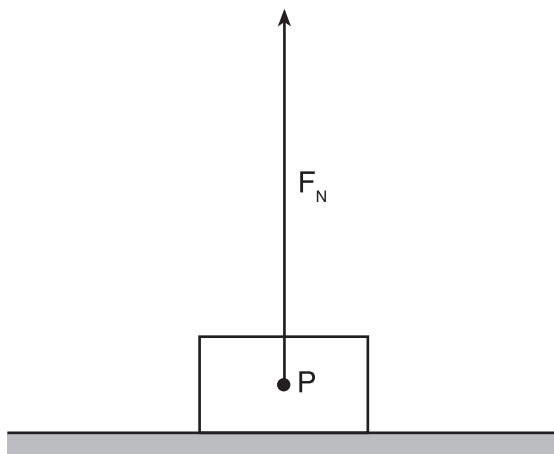

Note: Allow credit if the student draws the correct vector from the box and *not* from point P .

- 62 [2] Allow a maximum of 2 credits. Refer to *Scoring Criteria for Calculations* in this rating guide.

Example of a 2-credit response:

$$F_f = \mu F_N$$

$$F_f = (0.30)(20. \text{ N})$$

$$F_f = 6.0 \text{ N}$$

- 63 [1] Allow 1 credit for 2.0 N *or* an answer that is consistent with the student's response to question 62.

- 64 [1] Allow 1 credit for 2.0 kg.

- 65** [2] Allow a maximum of 2 credits. Refer to *Scoring Criteria for Calculations* in this rating guide.

Example of a 2-credit response:

$$a = \frac{F_{net}}{m}$$

$$a = \frac{2.0 \text{ N}}{2.0 \text{ kg}}$$

$$a = 1.0 \text{ m/s}^2$$

Note: Allow credit for an answer that is consistent with the student's responses to questions 63 and 64.

- 66** [2] Allow a maximum of 2 credits. Refer to *Scoring Criteria for Calculations* in this rating guide.

Example of a 2-credit response:

$$PE_s = \frac{1}{2} kx^2$$

$$PE_s = \frac{1}{2} (150 \text{ N/m})(0.050 \text{ m})^2$$

$$PE_s = 0.19 \text{ J or } 1.9 \times 10^{-1} \text{ J or } 0.1875 \text{ J}$$

- 67** [2] Allow a maximum of 2 credits. Refer to *Scoring Criteria for Calculations* in this rating guide.

Example of a 2-credit response:

$$\Delta PE = mg\Delta h$$

$$\Delta h = \frac{\Delta PE}{mg}$$

$$\Delta h = \frac{0.19 \text{ J}}{0.020 \text{ kg}(9.81 \text{ m/s}^2)}$$

$$\Delta h = 0.97 \text{ m}$$

Note: Allow credit for an answer that is consistent with the student's response to question 66.

68 [1] Allow 1 credit for $17^\circ \pm 2^\circ$.

69 [2] Allow a maximum of 2 credits. Refer to *Scoring Criteria for Calculations* in this rating guide.

Example of a 2-credit response:

$$n_1 \sin \theta_1 = n_2 \sin \theta_2$$

$$\sin \theta_2 = \frac{n_1 \sin \theta_1}{n_2}$$

$$\sin \theta_2 = \frac{1.00 \sin 17^\circ}{1.46}$$

$$\theta_2 = 12^\circ \text{ or } 11.6^\circ$$

Note: Allow credit for an answer that is consistent with the student's response to question 68.

- 70** [1] Allow 1 credit for drawing the refracted ray at an angle of $12^\circ \pm 2^\circ$, *or* an answer that is consistent with the student’s response to question 69.
- 71** [1] Allow 1 credit for drawing the reflected ray at an angle of $17^\circ \pm 2^\circ$, *or* an answer that is consistent with the student’s response to question 68.

Example of a 2-credit response for questions 70 and 71:

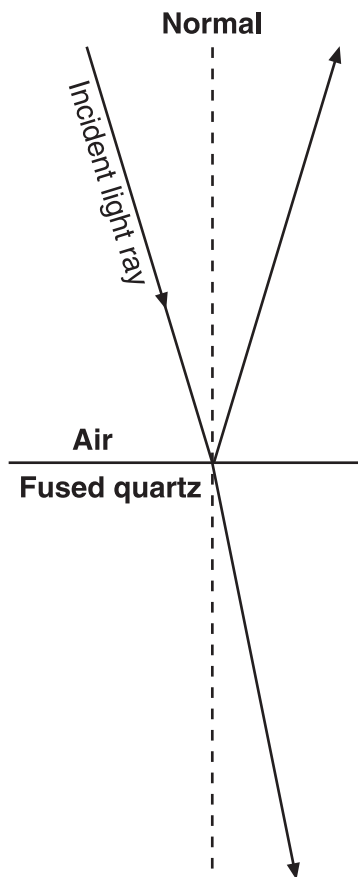

Note: Rays do *not* have to have arrows to receive credit.

- 72 [2] Allow a maximum of 2 credits. Refer to *Scoring Criteria for Calculations* in this rating guide.

Example of a 2-credit response:

$$E_{\text{photon}} = hf$$

$$E_{\text{photon}} = (6.63 \times 10^{-34} \text{ J}\cdot\text{s}) (5.02 \times 10^{14} \text{ Hz})$$

$$E_{\text{photon}} = 3.33 \times 10^{-19} \text{ J}$$

- 73 [1] Allow 1 credit for 2.08 eV *or* an answer that is consistent with the student's response to question 72.
- 74 [1] Allow 1 credit for $n = 3$ *or* an answer that is consistent with the student's response to question 73.

Regents Examination in Physical Setting/Physics

June 2007

Chart for Converting Total Test Raw Scores to Final Examination Scores (Scaled Scores)

The *Chart for Determining the Final Examination Score for the June 2007 Regents Examination in Physical Setting/Physics* will be posted on the Department's web site <http://www.emsc.nysed.gov/osa/> on Thursday, June 21, 2007. Conversion charts provided for previous administrations of the Regents Examination in Physical Setting/Physics must NOT be used to determine students' final scores for this administration.

On-line Submission of Teacher Evaluations of the Test to the Department

Suggestions and feedback from teachers provide an important contribution to the test development process. The Department provides an on-line evaluation form for State assessments. It contains spaces for teachers to respond to several specific questions and to make suggestions. Instructions for completing the evaluation form are as follows:

1. Go to www.emsc.nysed.gov/osa/exameval.
2. Select the test title.
3. Complete the required demographic fields.
4. Complete each evaluation question and provide comments in the space provided.
5. Click the SUBMIT button at the bottom of the page to submit the completed form.

Map to Core Curriculum

June 2007 Physical Setting/Physics			
Question Numbers			
Key Ideas	Part A	Part B	Part C
Standard 1			
Math Key Idea 1	2,7,8,9,11,12,14,17,19,20, 25,35	38,39,40,48,59,60	62,63,64,65,66,69, 72,73
Math Key Idea 2		41,43,44	
Math Key Idea 3		46	
Sci. Inq. Key Idea 1			
Sci. Inq. Key Idea 2			
Sci. Inq. Key Idea 3	11	40,49,50,51	67,68
Eng. Des. Key Idea 1			
Standard 2			
Key Idea 1			
Key Idea 2			
Standard 6			
Key Idea 1			
Key Idea 2	4,18,22,23,29	47,55,56,57	61,68,70,71
Key Idea 3		36	
Key Idea 4		53	
Key Idea 5			
Key Idea 6			
Standard 7			
Key Idea 1			
Key Idea 2			
Standard 4 Process Skills			
4.1	16,18	43,44,54,58	67
4.3			68,69,70,71
5.1	6,7	42,52,55	61
5.3		45	74
Standard 4			
4.1	11,12,13,15,16,17,18,19,20	43,44,54,58,59,60	66,67
4.3	21,22,23,24,25,26,27,28,29, 30,31	49,50,51	68,69,70,71
5.1	1,2,3,4,5,6,7,8,9,10,14	38,39,40,41,42,47, 48,52,53,55,56,57	61,62,63,64,65
5.3	32,33,34,35	45,46	72,73,74



Regents Examination in Physical Setting / Physics June 2007

Chart for Converting Total Test Raw Scores to
Final Examination Scores (Scaled Scores)

Raw Score	Scaled Score	Raw Score	Scaled Score	Raw Score	Scaled Score	Raw Score	Scaled Score
85	100	63	81	41	60	19	31
84	99	62	80	40	58	18	29
83	98	61	79	39	57	17	28
82	97	60	78	38	56	16	26
81	96	59	77	37	55	15	25
80	95	58	76	36	54	14	23
79	95	57	75	35	53	13	22
78	94	56	75	34	51	12	20
77	93	55	74	33	50	11	18
76	92	54	73	32	49	10	17
75	91	53	72	31	48	9	15
74	90	52	71	30	46	8	14
73	89	51	70	29	45	7	12
72	89	50	69	28	44	6	10
71	88	49	68	27	42	5	9
70	87	48	67	26	41	4	7
69	86	47	66	25	40	3	5
68	85	46	65	24	38	2	4
67	84	45	64	23	37	1	2
66	83	44	63	22	35	0	0
65	82	43	62	21	34		
64	82	42	61	20	32		

To determine the student's final examination score, find the student's total test raw score in the column labeled "Raw Score" and then locate the scaled score that corresponds to that raw score. The scaled score is the student's final examination score. Enter this score in the space labeled "Final Score" on the student's answer sheet.

All student answer papers that receive a scaled score of 60 through 64 **must** be scored a second time. For the second scoring, a different committee of teachers may score the student's paper or the original committee may score the paper, except that no teacher may score the same open-ended questions that he/she scored in the first rating of the paper. The school principal is responsible for assuring that the student's final examination score is based on a fair, accurate and reliable scoring of the student's answer paper.

Because scaled scores corresponding to raw scores in the conversion chart may change from one examination to another, it is crucial that for each administration, the conversion chart provided for that administration be used to determine the student's final score. The chart above is usable only for this administration of the Physical Setting/Physics Examination.