

The University of the State of New York
REGENTS HIGH SCHOOL EXAMINATION

PHYSICAL SETTING
PHYSICS

Wednesday, June 25, 2008 — 9:15 a.m. to 12:15 p.m., only

The answer sheet for Part A and Part B–1 is the last page of this examination booklet. Turn to the last page and fold it along the perforations. Then, slowly and carefully, tear off the answer sheet and fill in the heading.

The answers to the questions in Part B–2 and Part C are to be written in your separate answer booklet. Be sure to fill in the heading on the front of your answer booklet.

You are to answer *all* questions in all parts of this examination according to the directions provided in the examination booklet. Record your answers to the Part A and Part B–1 multiple-choice questions on your separate answer sheet. Write your answers to the Part B–2 and Part C questions in your answer booklet. All work should be written in pen, except for graphs and drawings, which should be done in pencil. You may use scrap paper to work out the answers to the questions, but be sure to record all your answers on the answer sheet and in the answer booklet.

When you have completed the examination, you must sign the statement printed at the end of your separate answer sheet, indicating that you had no unlawful knowledge of the questions or answers prior to the examination and that you have neither given nor received assistance in answering any of the questions during the examination. Your answer sheet and answer booklet cannot be accepted if you fail to sign this declaration.

Notice . . .

A scientific or graphing calculator, a centimeter ruler, a protractor, and a copy of the *2006 Edition Reference Tables for Physical Setting/Physics*, which you may need to answer some questions in this examination, must be available for your use while taking this examination.

The use of any communications device is strictly prohibited when taking this examination. If you use any communications device, no matter how briefly, your examination will be invalidated and no score will be calculated for you.

DO NOT OPEN THIS EXAMINATION BOOKLET UNTIL THE SIGNAL IS GIVEN.

Part A

Answer all questions in this part.

Directions (1–35): For *each* statement or question, write on the separate answer sheet the *number* of the word or expression that, of those given, best completes the statement or answers the question.

- 1 The speedometer in a car does *not* measure the car's velocity because velocity is a
 - (1) vector quantity and has a direction associated with it
 - (2) vector quantity and does not have a direction associated with it
 - (3) scalar quantity and has a direction associated with it
 - (4) scalar quantity and does not have a direction associated with it
- 2 A projectile launched at an angle of 45° above the horizontal travels through the air. Compared to the projectile's theoretical path with no air friction, the actual trajectory of the projectile with air friction is
 - (1) lower and shorter
 - (2) lower and longer
 - (3) higher and shorter
 - (4) higher and longer
- 3 Cart *A* has a mass of 2 kilograms and a speed of 3 meters per second. Cart *B* has a mass of 3 kilograms and a speed of 2 meters per second. Compared to the inertia and magnitude of momentum of cart *A*, cart *B* has
 - (1) the same inertia and a smaller magnitude of momentum
 - (2) the same inertia and the same magnitude of momentum
 - (3) greater inertia and a smaller magnitude of momentum
 - (4) greater inertia and the same magnitude of momentum
- 4 Approximately how much time does it take light to travel from the Sun to Earth?
 - (1) 2.00×10^{-3} s
 - (2) 1.28×10^0 s
 - (3) 5.00×10^2 s
 - (4) 4.50×10^{19} s
- 5 A rock falls from rest a vertical distance of 0.72 meter to the surface of a planet in 0.63 second. The magnitude of the acceleration due to gravity on the planet is
 - (1) 1.1 m/s^2
 - (2) 2.3 m/s^2
 - (3) 3.6 m/s^2
 - (4) 9.8 m/s^2
- 6 Two stones, *A* and *B*, are thrown horizontally from the top of a cliff. Stone *A* has an initial speed of 15 meters per second and stone *B* has an initial speed of 30. meters per second. Compared to the time it takes stone *A* to reach the ground, the time it takes stone *B* to reach the ground is
 - (1) the same
 - (2) twice as great
 - (3) half as great
 - (4) four times as great
- 7 The speed of an object undergoing constant acceleration increases from 8.0 meters per second to 16.0 meters per second in 10. seconds. How far does the object travel during the 10. seconds?
 - (1) 3.6×10^2 m
 - (2) 1.6×10^2 m
 - (3) 1.2×10^2 m
 - (4) 8.0×10^1 m
- 8 A 1200-kilogram space vehicle travels at 4.8 meters per second along the level surface of Mars. If the magnitude of the gravitational field strength on the surface of Mars is 3.7 newtons per kilogram, the magnitude of the normal force acting on the vehicle is
 - (1) 320 N
 - (2) 930 N
 - (3) 4400 N
 - (4) 5800 N

9 Which diagram represents a box in equilibrium?

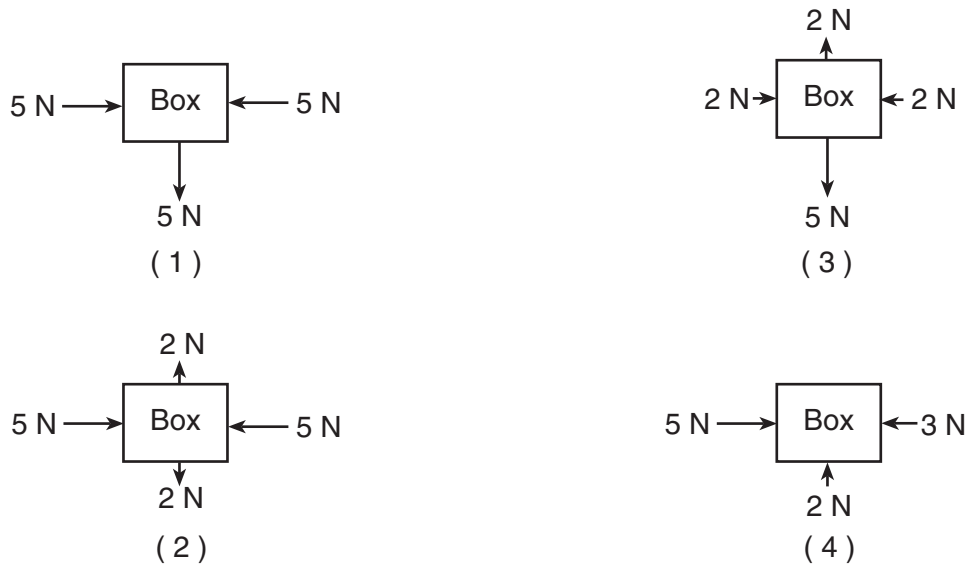

10 The diagram below shows an object moving counterclockwise around a horizontal, circular track.

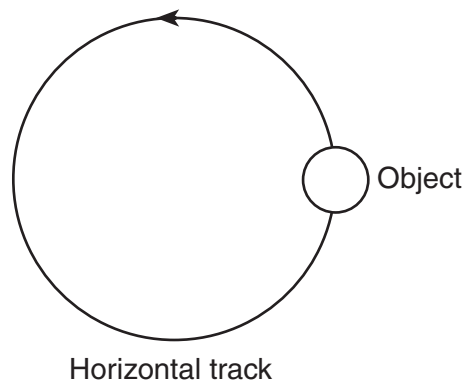

Which diagram represents the direction of both the object's velocity and the centripetal force acting on the object when it is in the position shown?

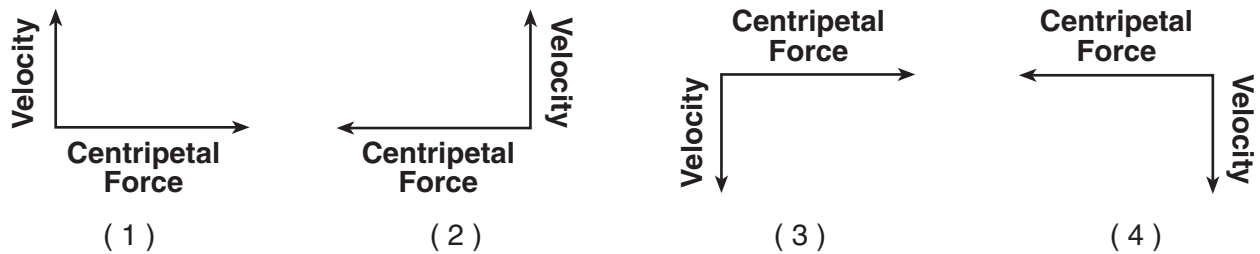

11 An airplane flies with a velocity of 750. kilometers per hour, 30.0° south of east. What is the magnitude of the eastward component of the plane's velocity?

- (1) 866 km/h (3) 433 km/h
 (2) 650. km/h (4) 375 km/h

12 An 80-kilogram skier slides on waxed skis along a horizontal surface of snow at constant velocity while pushing with his poles. What is the horizontal component of the force pushing him forward?

- (1) 0.05 N (3) 40 N
 (2) 0.4 N (4) 4 N

13 A 1750-kilogram car travels at a constant speed of 15.0 meters per second around a horizontal, circular track with a radius of 45.0 meters. The magnitude of the centripetal force acting on the car is

- (1) 5.00 N (3) 8750 N
 (2) 583 N (4) 3.94×10^5 N

14 A 0.45-kilogram football traveling at a speed of 22 meters per second is caught by an 84-kilogram stationary receiver. If the football comes to rest in the receiver's arms, the magnitude of the impulse imparted to the receiver by the ball is

- (1) 1800 N•s (3) 4.4 N•s
 (2) 9.9 N•s (4) 3.8 N•s

Note that question 15 has only three choices.

15 A carpenter hits a nail with a hammer. Compared to the magnitude of the force the hammer exerts on the nail, the magnitude of the force the nail exerts on the hammer during contact is

- (1) less
 (2) greater
 (3) the same

16 As a meteor moves from a distance of 16 Earth radii to a distance of 2 Earth radii from the center of Earth, the magnitude of the gravitational force between the meteor and Earth becomes

- (1) $\frac{1}{8}$ as great (3) 64 times as great
 (2) 8 times as great (4) 4 times as great

17 A 60.-kilogram student climbs a ladder a vertical distance of 4.0 meters in 8.0 seconds. Approximately how much total work is done against gravity by the student during the climb?

- (1) 2.4×10^3 J (3) 2.4×10^2 J
 (2) 2.9×10^2 J (4) 3.0×10^1 J

18 A car travels at constant speed v up a hill from point A to point B, as shown in the diagram below.

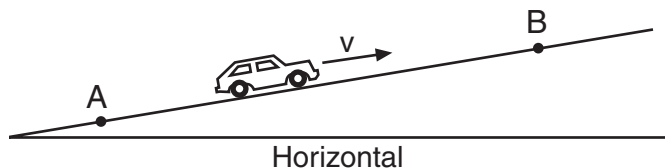

As the car travels from A to B, its gravitational potential energy

- (1) increases and its kinetic energy decreases
 (2) increases and its kinetic energy remains the same
 (3) remains the same and its kinetic energy decreases
 (4) remains the same and its kinetic energy remains the same

19 What is the maximum amount of work that a 6000.-watt motor can do in 10. seconds?

- (1) 6.0×10^1 J (3) 6.0×10^3 J
 (2) 6.0×10^2 J (4) 6.0×10^4 J

20 Three resistors, 4 ohms, 6 ohms, and 8 ohms, are connected in parallel in an electric circuit. The equivalent resistance of the circuit is

- (1) less than 4 Ω
 (2) between 4 Ω and 8 Ω
 (3) between 10. Ω and 18 Ω
 (4) 18 Ω

Note that question 21 has only three choices.

21 An electric circuit contains a variable resistor connected to a source of constant voltage. As the resistance of the variable resistor is increased, the power dissipated in the circuit

- (1) decreases
 (2) increases
 (3) remains the same

- 22 An electron is located in the electric field between two parallel metal plates as shown in the diagram below.

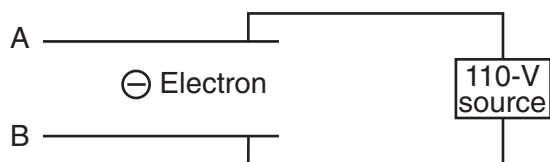

If the electron is attracted to plate A, then plate A is charged

- (1) positively, and the electric field is directed from plate A toward plate B
 - (2) positively, and the electric field is directed from plate B toward plate A
 - (3) negatively, and the electric field is directed from plate A toward plate B
 - (4) negatively, and the electric field is directed from plate B toward plate A
- 23 A potential difference of 10.0 volts exists between two points, A and B, within an electric field. What is the magnitude of charge that requires 2.0×10^{-2} joule of work to move it from A to B?
- (1) 5.0×10^2 C
 - (2) 2.0×10^{-1} C
 - (3) 5.0×10^{-2} C
 - (4) 2.0×10^{-3} C
- 24 A circuit consists of a resistor and a battery. Increasing the voltage of the battery while keeping the temperature of the circuit constant would result in an increase in
- (1) current, only
 - (2) resistance, only
 - (3) both current and resistance
 - (4) neither current nor resistance
- 25 The time required for a wave to complete one full cycle is called the wave's
- (1) frequency
 - (2) period
 - (3) velocity
 - (4) wavelength
- 26 An electromagnetic AM-band radio wave could have a wavelength of
- (1) 0.005 m
 - (2) 5 m
 - (3) 500 m
 - (4) 5 000 000 m

- 27 The diagram below represents a transverse wave.

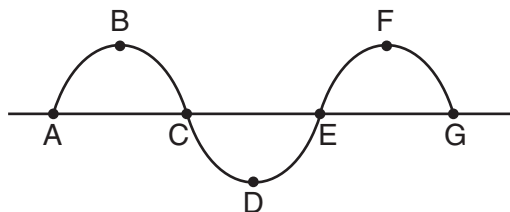

The wavelength of the wave is equal to the distance between points

- (1) A and G
 - (2) B and F
 - (3) C and E
 - (4) D and F
- 28 When a light wave enters a new medium and is refracted, there must be a change in the light wave's
- (1) color
 - (2) frequency
 - (3) period
 - (4) speed
- 29 The speed of light in a piece of plastic is 2.00×10^8 meters per second. What is the absolute index of refraction of this plastic?
- (1) 1.00
 - (2) 0.670
 - (3) 1.33
 - (4) 1.50
- 30 Wave X travels eastward with frequency f and amplitude A . Wave Y, traveling in the same medium, interacts with wave X and produces a standing wave. Which statement about wave Y is correct?
- (1) Wave Y must have a frequency of f , an amplitude of A , and be traveling eastward.
 - (2) Wave Y must have a frequency of $2f$, an amplitude of $3A$, and be traveling eastward.
 - (3) Wave Y must have a frequency of $3f$, an amplitude of $2A$, and be traveling westward.
 - (4) Wave Y must have a frequency of f , an amplitude of A , and be traveling westward.

31 The diagram below represents two pulses approaching each other from opposite directions in the same medium.



Which diagram best represents the medium after the pulses have passed through each other?

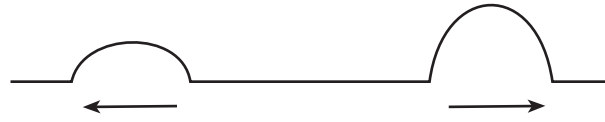

(1)

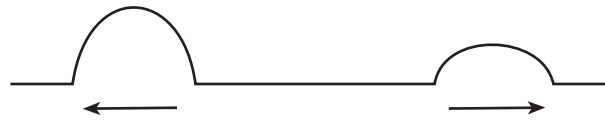

(2)



(3)

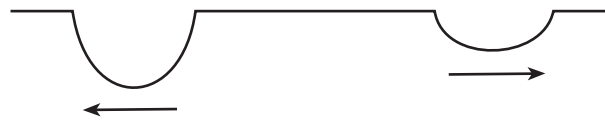

(4)

32 A car's horn is producing a sound wave having a constant frequency of 350 hertz. If the car moves toward a stationary observer at constant speed, the frequency of the car's horn detected by this observer may be

- (1) 320 Hz (3) 350 Hz
 (2) 330 Hz (4) 380 Hz

33 A mercury atom in the ground state absorbs 20.00 electronvolts of energy and is ionized by losing an electron. How much kinetic energy does this electron have after the ionization?

- (1) 6.40 eV (3) 10.38 eV
 (2) 9.62 eV (4) 13.60 eV

34 Which fundamental force is primarily responsible for the attraction between protons and electrons?

- (1) strong (3) gravitational
 (2) weak (4) electromagnetic

35 The total conversion of 1.00 kilogram of the Sun's mass into energy yields

- (1) 9.31×10^2 MeV (3) 3.00×10^8 J
 (2) 8.38×10^{19} MeV (4) 9.00×10^{16} J

Part B-1

Answer all questions in this part.

Directions (36–51): For each statement or question, write on the separate answer sheet the number of the word or expression that, of those given, best completes the statement or answers the question.

36 The mass of a paper clip is approximately

- (1) 1×10^6 kg (3) 1×10^{-3} kg
 (2) 1×10^3 kg (4) 1×10^{-6} kg

37 The graph below represents the displacement of an object moving in a straight line as a function of time.

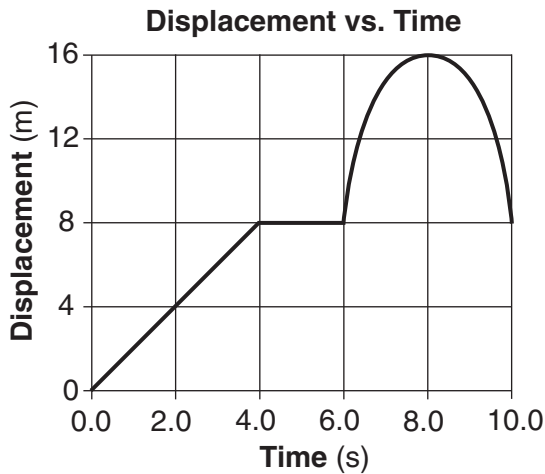

What was the total distance traveled by the object during the 10.0-second time interval?

- (1) 0 m (3) 16 m
 (2) 8 m (4) 24 m

38 Which diagram best represents the gravitational forces, F_g , between a satellite, S, and Earth?

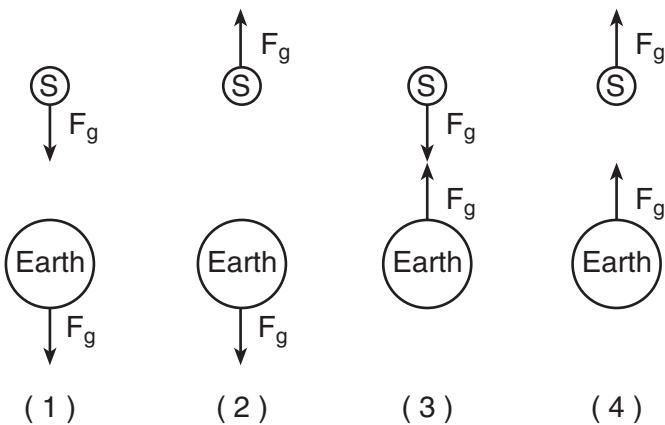

39 A block weighing 10.0 newtons is on a ramp inclined at 30.0° to the horizontal. A 3.0-newton force of friction, F_f , acts on the block as it is pulled up the ramp at constant velocity with force F , which is parallel to the ramp, as shown in the diagram below.

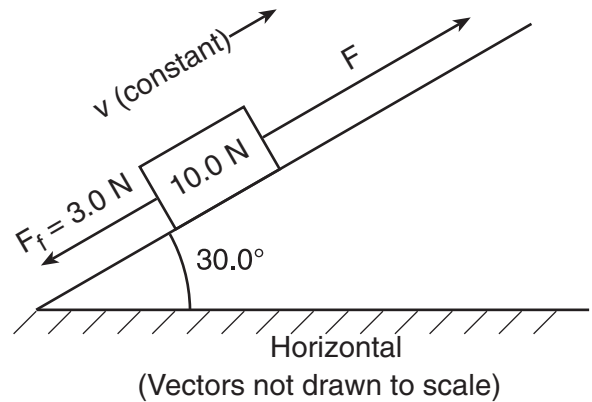

What is the magnitude of force F ?

- (1) 7.0 N (3) 10. N
 (2) 8.0 N (4) 13 N

40 A 25-newton horizontal force northward and a 35-newton horizontal force southward act concurrently on a 15-kilogram object on a frictionless surface. What is the magnitude of the object's acceleration?

- (1) 0.67 m/s^2 (3) 2.3 m/s^2
 (2) 1.7 m/s^2 (4) 4.0 m/s^2

41 The diagram below represents two concurrent forces.



Which vector represents the force that will produce equilibrium with these two forces?

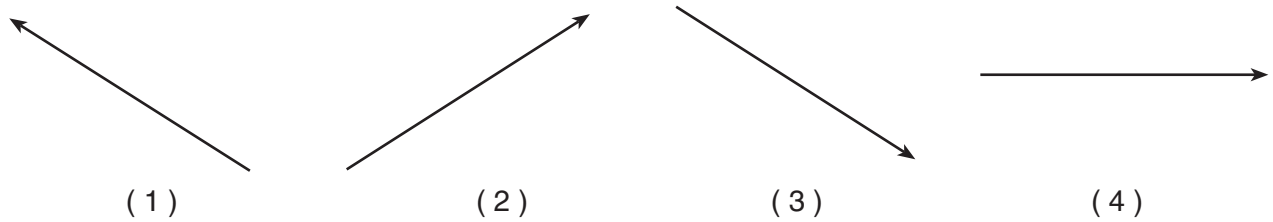

42 Which graph best represents the relationship between the magnitude of the centripetal acceleration and the speed of an object moving in a circle of constant radius?

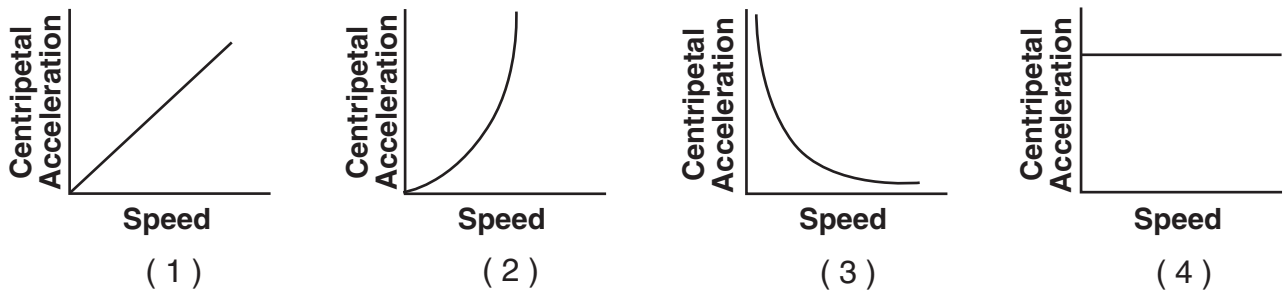

43 The diagram below represents two masses before and after they collide. Before the collision, mass m_A is moving to the right with speed v , and mass m_B is at rest. Upon collision, the two masses stick together.



Which expression represents the speed, v' , of the masses after the collision? [Assume no outside forces are acting on m_A or m_B .]

(1) $\frac{m_A + m_B v}{m_A}$

(3) $\frac{m_B v}{m_A + m_B}$

(2) $\frac{m_A + m_B}{m_A v}$

(4) $\frac{m_A v}{m_A + m_B}$

44 Which combination of fundamental units can be used to express energy?

- (1) $\text{kg}\cdot\text{m}/\text{s}$ (3) $\text{kg}\cdot\text{m}/\text{s}^2$
 (2) $\text{kg}\cdot\text{m}^2/\text{s}$ (4) $\text{kg}\cdot\text{m}^2/\text{s}^2$

45 An object is thrown vertically upward. Which pair of graphs best represents the object's kinetic energy and gravitational potential energy as functions of its displacement while it rises?

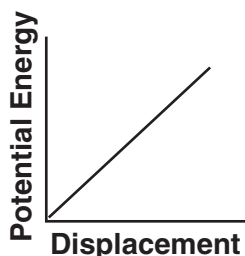
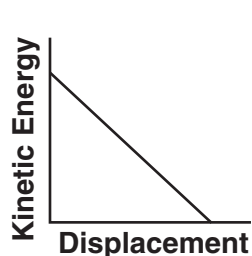

(1)

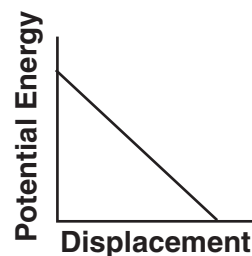
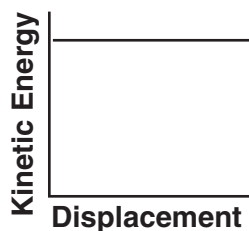

(3)

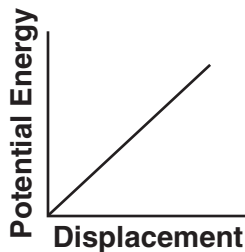
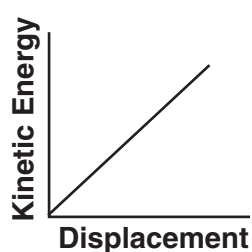

(2)

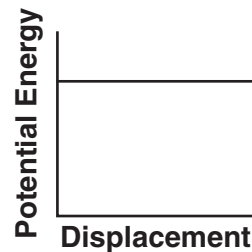
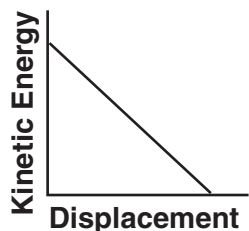

(4)

46 Charge flowing at the rate of 2.50×10^{16} elementary charges per second is equivalent to a current of

- (1) 2.50×10^{13} A (3) 4.00×10^{-3} A
 (2) 6.25×10^5 A (4) 2.50×10^{-3} A

47 An electric drill operating at 120. volts draws a current of 3.00 amperes. What is the total amount of electrical energy used by the drill during 1.00 minute of operation?

- (1) 2.16×10^4 J (3) 3.60×10^2 J
 (2) 2.40×10^3 J (4) 4.00×10^1 J

48 The diagram below represents a transverse wave traveling to the right through a medium. Point A represents a particle of the medium.

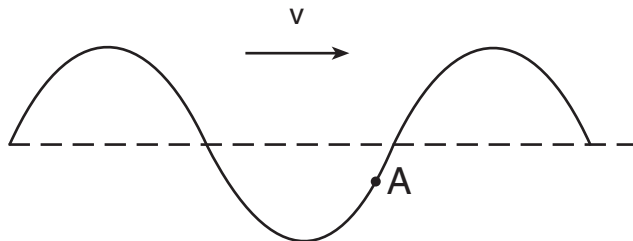

In which direction will particle A move in the next instant of time?

- (1) up
- (2) down
- (3) left
- (4) right

49 Which graph best represents the relationship between photon energy and photon frequency?

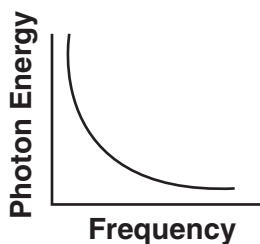

(1)

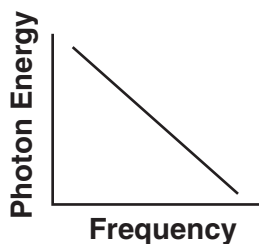

(2)

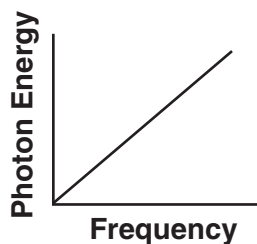

(3)

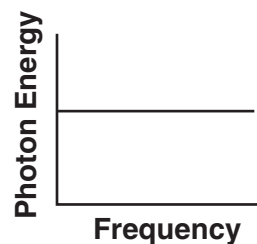

(4)

Base your answers to questions 50 and 51 on the table below, which shows data about various subatomic particles.

Subatomic Particle Table

Symbol	Name	Quark Content	Electric Charge	Mass (GeV/c ²)
p	proton	uud	+1	0.938
\bar{p}	antiproton	$\bar{u}\bar{u}\bar{d}$	-1	0.938
n	neutron	udd	0	0.940
λ	lambda	uds	0	1.116
Ω^-	omega	sss	-1	1.672

50 Which particle listed on the table has the opposite charge of, and is more massive than, a proton?

- (1) antiproton
- (2) neutron
- (3) lambda
- (4) omega

51 All the particles listed on the table are classified as

- (1) mesons
- (2) hadrons
- (3) antimatter
- (4) leptons

Part B-2

Answer all questions in this part.

Directions (52–61): Record your answers in the spaces provided in your answer booklet.

- 52 The graph below represents the velocity of an object traveling in a straight line as a function of time.

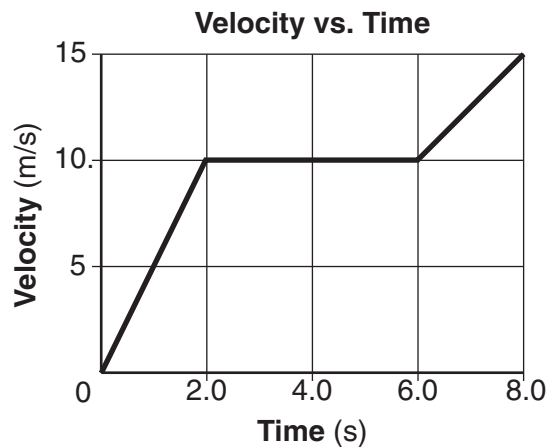

Determine the magnitude of the total displacement of the object at the end of the first 6.0 seconds. [1]

Base your answers to questions 53 and 54 on the information below.

A 65-kilogram pole vaulter wishes to vault to a height of 5.5 meters.

- 53 Calculate the *minimum* amount of kinetic energy the vaulter needs to reach this height if air friction is neglected and all the vaulting energy is derived from kinetic energy. [Show all work, including the equation and substitution with units.] [2]
- 54 Calculate the speed the vaulter must attain to have the necessary kinetic energy. [Show all work, including the equation and substitution with units.] [2]
-

Base your answers to questions 55 through 57 on the information and vector diagram below.

A dog walks 8.0 meters due north and then 6.0 meters due east.

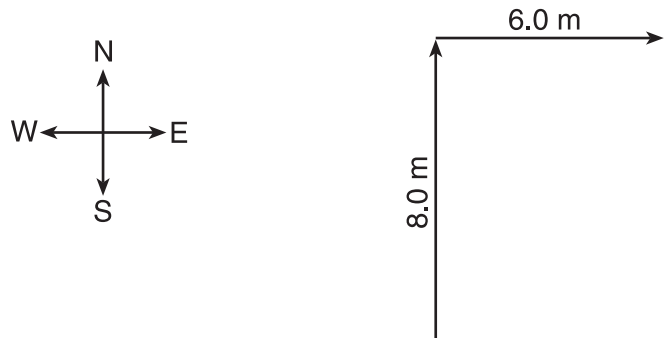

- 55 Using a metric ruler and the vector diagram, determine the scale used in the diagram. [1]
- 56 On the diagram *in your answer booklet*, construct the resultant vector that represents the dog's total displacement. [1]
- 57 Determine the magnitude of the dog's total displacement. [1]

-
- 58 Two small identical metal spheres, *A* and *B*, on insulated stands, are each given a charge of $+2.0 \times 10^{-6}$ coulomb. The distance between the spheres is 2.0×10^{-1} meter. Calculate the magnitude of the electrostatic force that the charge on sphere *A* exerts on the charge on sphere *B*. [Show all work, including the equation and substitution with units.] [2]

Base your answers to questions 59 and 60 on the information and diagram below.

A 10.0-meter length of copper wire is at 20°C. The radius of the wire is 1.0×10^{-3} meter.

Cross Section of Copper Wire

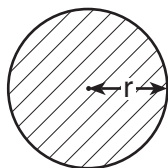

$$r = 1.0 \times 10^{-3} \text{ m}$$

59 Determine the cross-sectional area of the wire. [1]

60 Calculate the resistance of the wire. [Show all work, including the equation and substitution with units.] [2]

61 The diagram in your answer booklet represents a transverse wave moving on a uniform rope with point A labeled as shown. On the diagram *in your answer booklet*, mark an **X** at the point on the wave that is 180° out of phase with point A. [1]

Part C

Answer all questions in this part.

Directions (62–76): Record your answers in the spaces provided in your answer booklet.

Base your answers to questions 62 through 64 on the information below.

A kicked soccer ball has an initial velocity of 25 meters per second at an angle of $40.^\circ$ above the horizontal, level ground. [Neglect friction.]

- 62 Calculate the magnitude of the vertical component of the ball's initial velocity. [Show all work, including the equation and substitution with units.] [2]
- 63 Calculate the maximum height the ball reaches above its initial position. [Show all work, including the equation and substitution with units.] [2]
- 64 On the diagram *in your answer booklet*, sketch the path of the ball's flight from its initial position at point *P* until it returns to level ground. [1]
-

Base your answers to questions 65 through 67 on the information and diagram below.

A 15-ohm resistor, R_1 , and a 30.-ohm resistor, R_2 , are to be connected in parallel between points *A* and *B* in a circuit containing a 90.-volt battery.

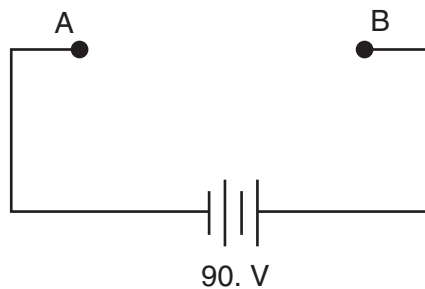

- 65 Complete the diagram *in your answer booklet* to show the two resistors connected in parallel between points *A* and *B*. [1]
- 66 Determine the potential difference across resistor R_1 . [1]
- 67 Calculate the current in resistor R_1 . [Show all work, including the equation and substitution with units.] [2]
-

Base your answers to questions 68 through 71 on the information and data table below.

The spring in a dart launcher has a spring constant of 140 newtons per meter. The launcher has six power settings, 0 through 5, with each successive setting having a spring compression 0.020 meter beyond the previous setting. During testing, the launcher is aligned to the vertical, the spring is compressed, and a dart is fired upward. The maximum vertical displacement of the dart in each test trial is measured. The results of the testing are shown in the table below.

Data Table

Power Setting	Spring Compression (m)	Dart's Maximum Vertical Displacement (m)
0	0.000	0.00
1	0.020	0.29
2	0.040	1.14
3	0.060	2.57
4	0.080	4.57
5	0.100	7.10

Directions (68–69): Using the information in the data table, construct a graph on the grid *in your answer booklet*, following the directions below.

68 Plot the data points for the dart's maximum vertical displacement versus spring compression. [1]

69 Draw the line or curve of best fit. [1]

70 Using information from your graph, calculate the energy provided by the compressed spring that causes the dart to achieve a maximum vertical displacement of 3.50 meters. [Show all work, including the equation and substitution with units.] [2]

71 Determine the magnitude of the force, in newtons, needed to compress the spring 0.040 meter. [1]

Base your answers to questions 72 through 74 on the information and diagram below.

A ray of monochromatic light having a frequency of 5.09×10^{14} hertz is incident on an interface of air and corn oil at an angle of 35° as shown. The ray is transmitted through parallel layers of corn oil and glycerol and is then reflected from the surface of a plane mirror, located below and parallel to the glycerol layer. The ray then emerges from the corn oil back into the air at point P .

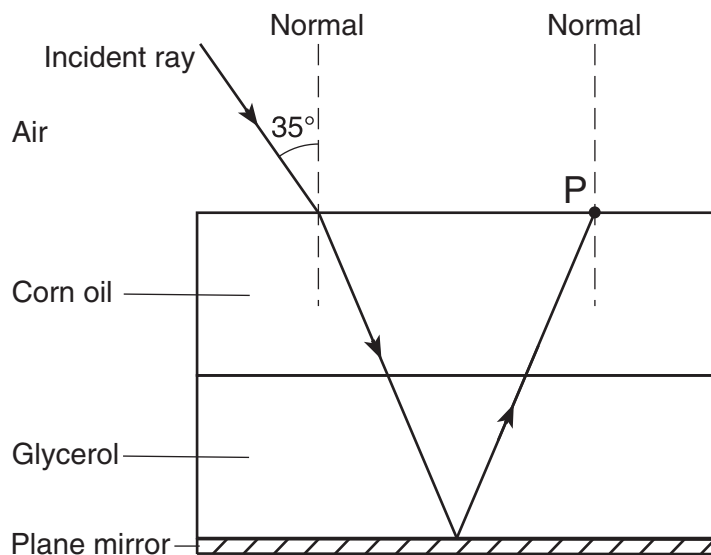

72 Calculate the angle of refraction of the light ray as it enters the corn oil from air. [Show all work, including the equation and the substitution with units.] [2]

73 Explain why the ray does *not* bend at the corn oil-glycerol interface. [1]

74 On the diagram *in your answer booklet*, use a protractor and straightedge to construct the refracted ray representing the light emerging at point P into air. [1]

Base your answers to questions 75 and 76 on the information and data table below.

In the first nuclear reaction using a particle accelerator, accelerated protons bombarded lithium atoms, producing alpha particles and energy. The energy resulted from the conversion of mass into energy. The reaction can be written as shown below.

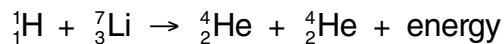

Data Table

Particle	Symbol	Mass (u)
proton	${}^1_1\text{H}$	1.007 83
lithium atom	${}^7_3\text{Li}$	7.016 00
alpha particle	${}^4_2\text{He}$	4.002 60

75 Determine the difference between the total mass of a proton plus a lithium atom, ${}^1_1\text{H} + {}^7_3\text{Li}$, and the total mass of two alpha particles, ${}^4_2\text{He} + {}^4_2\text{He}$, in universal mass units. [1]

76 Determine the energy in megaelectronvolts produced in the reaction of a proton with a lithium atom. [1]

The University of the State of New York

REGENTS HIGH SCHOOL EXAMINATION

PHYSICAL SETTING
PHYSICS

Wednesday, June 25, 2008 — 9:15 a.m. to 12:15 p.m., only

ANSWER SHEET

Student Sex: Male Female Grade

Teacher School

Record your answers to Part A and Part B-1 on this answer sheet.

Part A

- 1 13 25
- 2 14 26
- 3 15 27
- 4 16 28
- 5 17 29
- 6 18 30
- 7 19 31
- 8 20 32
- 9 21 33
- 10 22 34
- 11 23 35
- 12 24

Part A Score

Part B-1

- 36 44
- 37 45
- 38 46
- 39 47
- 40 48
- 41 49
- 42 50
- 43 51

Part B-1 Score

Write your answers to Part B-2 and Part C in your answer booklet.

The declaration below should be signed when you have completed the examination.

I do hereby affirm, at the close of this examination, that I had no unlawful knowledge of the questions or answers prior to the examination and that I have neither given nor received assistance in answering any of the questions during the examination.

Signature

Tear Here

Tear Here

Tear Here

Tear Here

PHYSICAL SETTING PHYSICS

Wednesday, June 25, 2008 — 9:15 a.m. to 12:15 p.m., only

ANSWER BOOKLET

Student..... Sex: Male
 Female
Teacher
School..... Grade

Answer all questions in Part B-2 and Part C. Record your answers in this booklet.

Part	Maximum Score	Student's Score
A	35	
B-1	16	
B-2	14	
C	20	
Total Written Test Score (Maximum Raw Score: 85)		<input type="text"/>
Final Score (from conversion chart)		<input type="text"/>
Raters' Initials: Rater 1 Rater 2		

Part B-2

52 _____ m

53

54

For Raters Only

52

53

54

For Raters
Only

55 1.0 cm = _____ m

55

56



56

57 _____ m

57

For Raters
Only

58

58

59 _____ m²

59

60

60

61

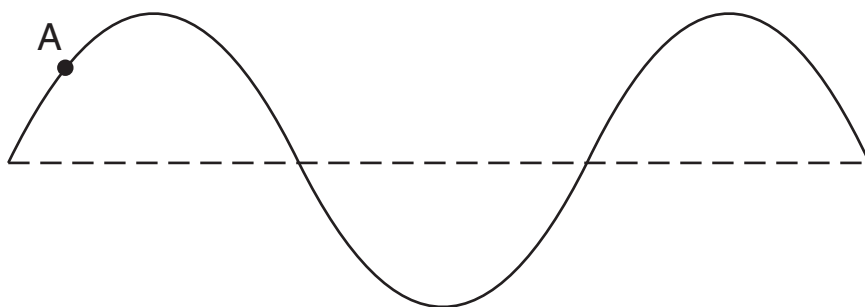

61

Total Score for
Part B-2

Part C

For Raters Only

62

62

63

63

64

64

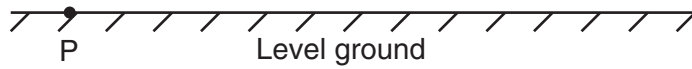

68-69

Dart's Maximum Vertical Displacement vs. Spring Compression

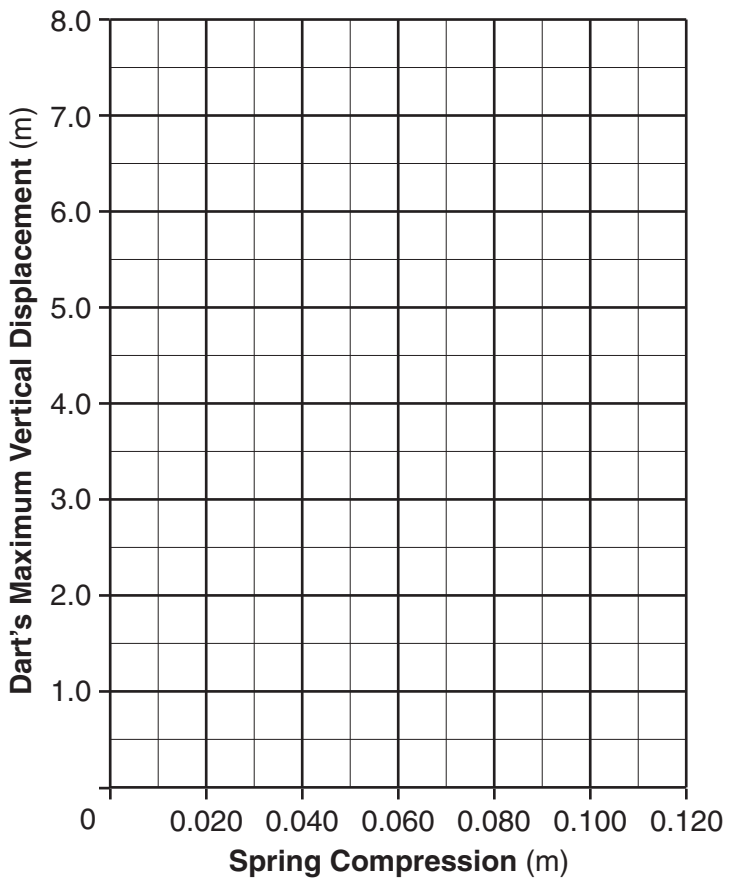

68

69

70

70

71 _____ N

71

For Raters Only

72

72

73

73

74

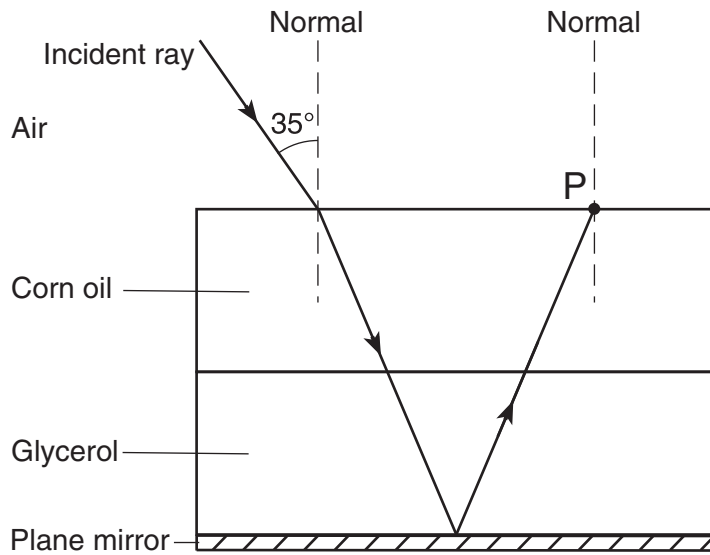

74

75 _____ u

75

76 _____ MeV

76

Total Score for Part C



Regents Examination in Physical Setting / Physics June 2008

Chart for Converting Total Test Raw Scores to
Final Examination Scores (Scale Scores)

Raw Score	Scale Score	Raw Score	Scale Score	Raw Score	Scale Score	Raw Score	Scale Score
85	100	63	80	41	58	19	30
84	99	62	79	40	57	18	29
83	98	61	78	39	56	17	28
82	97	60	77	38	55	16	26
81	96	59	76	37	54	15	25
80	95	58	75	36	52	14	23
79	94	57	74	35	51	13	22
78	94	56	73	34	50	12	20
77	93	55	72	33	49	11	19
76	92	54	71	32	48	10	17
75	91	53	71	31	46	9	15
74	90	52	70	30	45	8	14
73	89	51	68	29	44	7	12
72	88	50	68	28	43	6	11
71	87	49	67	27	41	5	9
70	86	48	65	26	40	4	7
69	86	47	64	25	39	3	5
68	85	46	63	24	37	2	4
67	84	45	62	23	36	1	2
66	83	44	61	22	35	0	0
65	82	43	60	21	33		
64	81	42	59	20	32		

To determine the student's final examination score, find the student's total test raw score in the column labeled "Raw Score" and then locate the scale score that corresponds to that raw score. The scale score is the student's final examination score. Enter this score in the space labeled "Final Score" on the student's answer sheet.

All student answer papers that receive a scale score of 60 through 64 **must** be scored a second time. For the second scoring, a different committee of teachers may score the student's paper or the original committee may score the paper, except that no teacher may score the same open-ended questions that he/she scored in the first rating of the paper. The school principal is responsible for assuring that the student's final examination score is based on a fair, accurate and reliable scoring of the student's answer paper.

Because scale scores corresponding to raw scores in the conversion chart may change from one examination to another, it is crucial that for each administration, the conversion chart provided for that administration be used to determine the student's final score. The chart above is usable only for this administration of the Physical Setting / Physics Examination.

FOR TEACHERS ONLY

The University of the State of New York
REGENTS HIGH SCHOOL EXAMINATION

PS-P

PHYSICAL SETTING/PHYSICS

Wednesday, June 25, 2008 — 9:15 a.m. to 12:15 p.m., only

SCORING KEY AND RATING GUIDE

Directions to the Teacher:

Refer to the directions on page 3 before rating student papers. Updated information regarding the rating of this examination may be posted on the New York State Education Department's web site during the rating period. Check this web site <http://www.emsc.nysed.gov/osa/> and select the link "Examination Scoring Information" for any recently posted information regarding this examination. This site should be checked before the rating process for this examination begins and several times throughout the Regents examination period.

Part A and Part B-1

Allow 1 credit for each correct response.

Part A			Part B-1	
1 1	13 3	25 2	36 3	44 4
2 1	14 2	26 3	37 4	45 1
3 4	15 3	27 2	38 3	46 3
4 3	16 3	28 4	39 2	47 1
5 3	17 1	29 4	40 1	48 2
6 1	18 2	30 4	41 3	49 3
7 3	19 4	31 2	42 2	50 4
8 3	20 1	32 4	43 4	51 2
9 2	21 1	33 2		
10 2	22 1	34 4		
11 2	23 4	35 4		
12 3	24 1			

Directions to the Teacher

Follow the procedures below for scoring student answer papers for the Physical Setting/Physics examination. Additional information about scoring is provided in the publication *Information for Scoring Regents Examinations in the Sciences*.

Use only *red* ink or *red* pencil in rating Regents papers. Do not attempt to *correct* the student's work by making insertions or changes of any kind.

On the detachable answer sheet for Part A and Part B–1, indicate by means of a checkmark each incorrect or omitted answer. In the box provided at the end of each part, record the number of questions the student answered correctly for that part.

Students' responses must be scored strictly according to the Scoring Key and Rating Guide. For open-ended questions, credit may be allowed for responses other than those given in the rating guide if the response is a scientifically accurate answer to the question and demonstrates adequate knowledge as indicated by the examples in the rating guide.

Fractional credit is *not* allowed. Only whole-number credit may be given to a response. Units need not be given when the wording of the questions allows such omissions.

Raters should enter the scores earned for Part A, Part B–1, Part B–2, and Part C on the appropriate lines in the box printed on the answer booklet, and then should add these four scores and enter the total in the box labeled "Total Written Test Score." Then, the student's raw score on the written test should be converted to a scaled score by using the conversion chart that will be posted on the Department's web site: <http://www.emsc.nysed.gov/osa/> on Wednesday, June 25, 2008. The student's scaled score should be entered in the labeled box on the student's answer booklet. The scaled score is the student's final examination score.

All student answer papers that receive a scaled score of 60 through 64 **must** be scored a second time. For the second scoring, a different committee of teachers may score the student's paper or the original committee may score the paper, except that no teacher may score the same open-ended questions that he/she scored in the first rating of the paper. The school principal is responsible for assuring that the student's final examination score is based on a fair, accurate, and reliable scoring of the student's answer paper.

Because scaled scores corresponding to raw scores in the conversion chart may change from one examination to another, it is crucial that for each administration, the conversion chart provided for that administration be used to determine the student's final score.

Please refer to the Department publication *Regents Examination in Physical Setting/Physics: Rating Guide for Parts B–2 and C*. This publication can be found on the New York State Education Department web site <http://www.emsc.nysed.gov/osa/scire/scirearch/phyratg02.pdf>. Teachers should become familiar with this guide before rating students' papers.

Scoring Criteria for Calculations

For each question requiring the student to show *all calculations, including the equation and substitution with units*, apply the following scoring criteria:

- Allow 1 credit for the equation and substitution of values with units. If the equation and/or substitution with units is not shown, do *not* allow this credit.
- Allow 1 credit for the correct answer (number and unit). If the number is given without the unit, do *not* allow this credit.
- Penalize a student only once per equation for omitting units.
- Allow full credit even if the answer is not expressed with the correct number of significant figures.

Part B–2

52 [1] Allow 1 credit for 50. m.

53 [2] Allow a maximum of 2 credits. Refer to *Scoring Criteria for Calculations* in this rating guide.

Example of a 2-credit response:

$$KE = \Delta PE = mg\Delta h$$

$$KE = (65 \text{ kg})(9.81 \text{ m/s}^2)(5.5 \text{ m})$$

$$KE = 3.5 \times 10^3 \text{ J}$$

54 [2] Allow a maximum of 2 credits. Refer to *Scoring Criteria for Calculations* in this rating guide.

Example of a 2-credit response:

$$KE = \frac{1}{2}mv^2$$

$$v = \sqrt{\frac{2KE}{m}}$$

$$v = \sqrt{\frac{2(3.5 \times 10^3 \text{ J})}{65 \text{ kg}}}$$

$$v = 10. \text{ m/s}$$

Note: Allow credit for an answer that is consistent with the student's response to question 53.

55 [1] Allow 1 credit for $1.0 \text{ cm} = 2.0 \text{ m} \pm 0.2 \text{ m}$.

56 [1] Allow 1 credit for drawing a vector $5.0 \text{ cm} \pm 0.2 \text{ cm}$ long, including an arrowhead at the end directed away from the starting point.

Example of a 1-credit response:

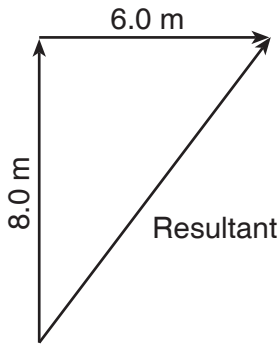

Note: The vectors need *not* be labeled to receive this credit.

57 [1] Allow 1 credit for $10. \text{ m} \pm 0.4 \text{ m}$.

Note: Allow credit for an answer that is consistent with the student's response to questions 55 and/or 56.

58 [2] Allow a maximum of 2 credits. Refer to the *Scoring Criteria for Calculations* in this rating guide.

Example of a 2-credit response:

$$F_e = \frac{kq_1 q_2}{r^2}$$

$$F_e = \frac{(8.99 \times 10^9 \text{ N} \cdot \text{m}^2 / \text{C}^2)(2.0 \times 10^{-6} \text{ C})(2.0 \times 10^{-6} \text{ C})}{(2.0 \times 10^{-1} \text{ m})^2}$$

$$F_e = 9.0 \times 10^{-1} \text{ N}$$

59 [1] Allow 1 credit for $3.1 \times 10^{-6} \text{ m}^2$.

60 [2] Allow a maximum of 2 credits. Refer to *Scoring Criteria for Calculations* in this rating guide.

Example of a 2-credit response:

$$R = \frac{\rho L}{A}$$

$$R = \frac{(1.72 \times 10^{-8} \Omega \cdot \text{m})(10.0 \text{ m})}{3.1 \times 10^{-6} \text{ m}^2}$$

$$R = 5.5 \times 10^{-2} \Omega$$

Note: Allow credit for an answer that is consistent with the student's response to question 59.

61 [1] Allow 1 credit for marking an **X** 180° out of phase with point A.

Example of a 1-credit response:

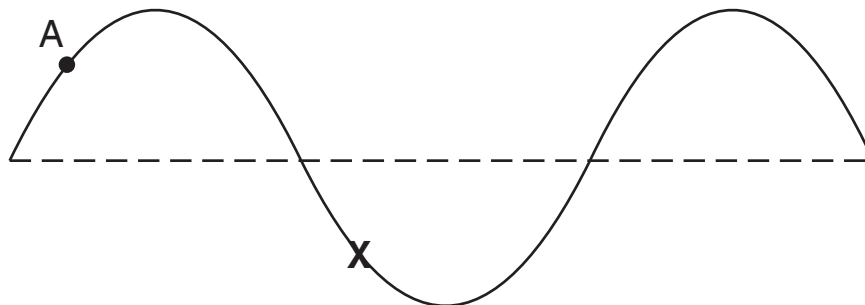

Part C

62 [2] Allow a maximum of 2 credits. Refer to *Scoring Criteria for Calculations* in this rating guide.

Example of a 2-credit response:

$$A_y = A \sin \theta$$

$$v_{iy} = (25 \text{ m/s})(\sin 40.^\circ)$$

$$v_{iy} = 16 \text{ m/s}$$

63 [2] Allow a maximum of 2 credits. Refer to *Scoring Criteria for Calculations* in this rating guide.

Example of a 2-credit response:

$$v_f^2 = v_i^2 + 2ad$$

$$d = \frac{v_f^2 - v_i^2}{2a}$$

$$d = \frac{(16 \text{ m/s})^2}{2(9.81 \text{ m/s}^2)}$$

$$d = 13 \text{ m}$$

Note: Allow credit for an answer that is consistent with the student's response to question 62.

64 [1] Allow 1 credit for drawing a generally parabolic path.

Example of a 1-credit response:

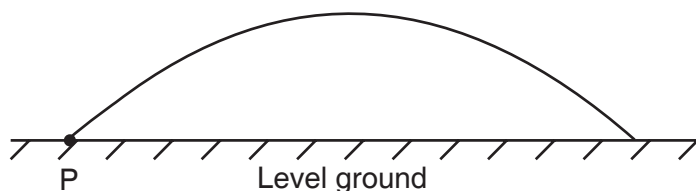

- 65 [1] Allow 1 credit for drawing two resistors in parallel, completing the circuit.

Example of a 1-credit response:

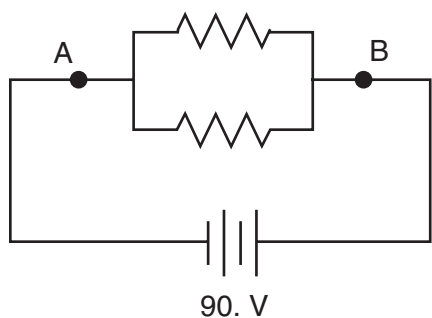

- 66 [1] Allow 1 credit for 90. V.

Note: Allow credit for an answer that is consistent with the student's response to question 65.

- 67 [2] Allow a maximum of 2 credits. Refer to *Scoring Criteria for Calculations* in this rating guide.

Example of a 2-credit response:

$$R = \frac{V}{I}$$

$$I = \frac{V}{R}$$

$$I = \frac{90. \text{ V}}{15 \ \Omega}$$

$$I = 6.0 \text{ A}$$

Note: Allow credit for an answer that is consistent with the student's response to question 66.

68 [1] Allow 1 credit for correctly plotting all data points ± 0.3 grid space.

69 [1] Allow 1 credit for drawing a line or curve of best fit.

Example of a 2-credit response for questions 68 and 69:

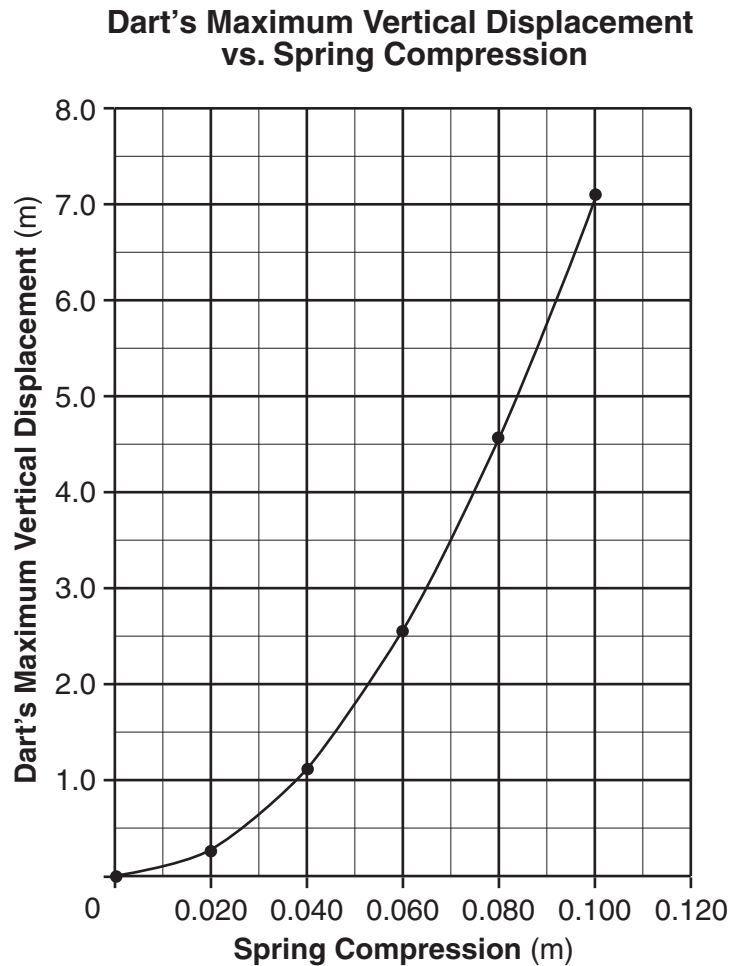

70 [2] Allow a maximum of 2 credits. Refer to *Scoring Criteria for Calculations* in this rating guide.

Example of a 2-credit response:

$$PE_s = \frac{1}{2} kx^2$$

$$PE_s = \frac{1}{2} (140 \text{ N/m})(0.070 \text{ m})^2$$

$$PE_s = 0.34 \text{ J}$$

Note: Allow credit for an answer that is consistent with the student's graph.

71 [1] Allow 1 credit for 5.6 N.

72 [2] Allow a maximum of 2 credits. Refer to *Scoring Criteria for Calculations* in this rating guide.

Example of a 2-credit response:

$$n_1 \sin \theta_1 = n_2 \sin \theta_2$$

$$\sin \theta_2 = \frac{n_1 \sin \theta_1}{n_2}$$

$$\sin \theta_2 = \frac{1.00 \sin 35^\circ}{1.47}$$

$$\theta_2 = 23^\circ$$

73 [1] Allow 1 credit. Acceptable responses include, but are not limited to:

- The light does not bend because light travels at the same speed in both layers.
- The absolute indices of refraction are the same.

74 [1] Allow 1 credit for drawing the refracted ray at an angle of $35^\circ \pm 2^\circ$ to the normal.

Example of a 1-credit response:

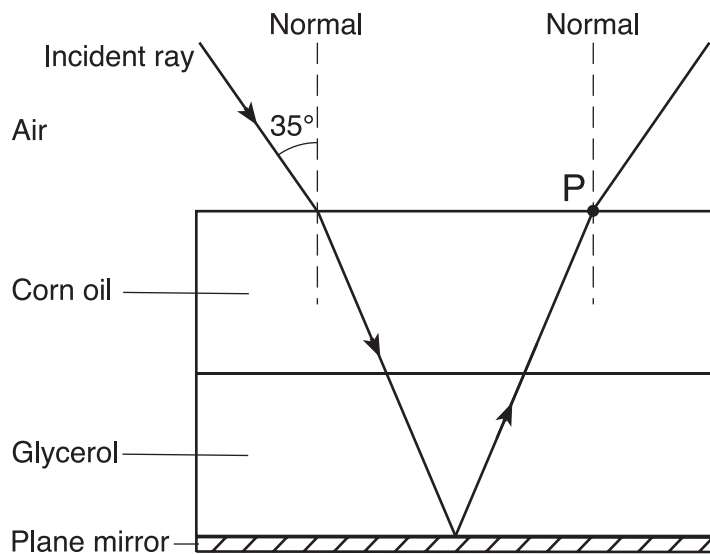

PHYSICAL SETTING/PHYSICS – *concluded*

75 [1] Allow 1 credit for 0.018 63 u.

76 [1] Allow 1 credit for 17.3 MeV.

Note: Allow credit for an answer that is consistent with the student's response to question 75.

Regents Examination in Physical Setting/Physics

June 2008

Chart for Converting Total Test Raw Scores to Final Examination Scores (Scaled Scores)

The *Chart for Determining the Final Examination Score for the June 2008 Regents Examination in Physical Setting/Physics* will be posted on the Department's web site <http://www.emsc.nysed.gov/osa/> on Wednesday, June 25, 2008. Conversion charts provided for previous administrations of the Regents Examination in Physical Setting/Physics must NOT be used to determine students' final scores for this administration.

Online Submission of Teacher Evaluations of the Test to the Department

Suggestions and feedback from teachers provide an important contribution to the test development process. The Department provides an online evaluation form for State assessments. It contains spaces for teachers to respond to several specific questions and to make suggestions. Instructions for completing the evaluation form are as follows:

1. Go to www.emsc.nysed.gov/osa/exameval.
2. Select the test title.
3. Complete the required demographic fields.
4. Complete each evaluation question and provide comments in the space provided.
5. Click the SUBMIT button at the bottom of the page to submit the completed form.

Map to Core Curriculum

June 2008 Physical Setting/Physics			
Question Numbers			
Key Ideas	Part A	Part B	Part C
Standard 1			
Math Key Idea 1	3,4,5,7,8,11,12,13,14,16,17,19, 23,29,35	39,40,41,43,46,47, 52,54,58,59,60	62,63,64,66,67,68, 69,70,71,72,75,76
Math Key Idea 2		42,45,49	
Math Key Idea 3		37	
Sci. Inq. Key Idea 1			
Sci. Inq. Key Idea 2			
Sci. Inq. Key Idea 3		38,48	
Eng. Des. Key Idea 1			
Standard 2			
Key Idea 1			
Key Idea 2			
Standard 6			
Key Idea 1			
Key Idea 2			
Key Idea 3		36	
Key Idea 4			
Key Idea 5			
Key Idea 6			
Standard 7			
Key Idea 1			
Key Idea 2			
Standard 4 Process Skills			
4.1		53,54	65,66
4.3	29	61	72,73,74
5.1		40,41,52,55,56,57	62
5.3			
Standard 4			
4.1	17,18,19,20,21,23,24	44,45,46,47,53,54, 59,60	65,66,67
4.3	25,26,27,28,29,30,31,32	48,61	72,73,74
5.1	1,2,3,4,5,6,7,8,9,10,11,12,13,14, 15,16,22	37,38,39,40,41,42, 43,52,55,56,57,58	62,63,64,68,69,70, 71
5.3	33,34,35	49,50,51	75,76